



AIRDUO NEXIA SP-CP

Технические характеристики

По вопросам продаж и поддержки обращайтесь:

Архангельск (8182)63-90-72

Астана +7(7172)727-132

Белгород (4722)40-23-64

Брянск (4832)59-03-52

Владивосток (423)249-28-31

Волгоград (844)278-03-48

Вологда (8172)26-41-59

Воронеж (473)204-51-73

Екатеринбург (343)384-55-89

Иваново (4932)77-34-06

Ижевск (3412)26-03-58

Казань (843)206-01-48

Калининград (4012)72-03-81

Калуга (4842)92-23-67

Кемерово (3842)65-04-62

Киров (8332)68-02-04

Краснодар (861)203-40-90

Красноярск (391)204-63-61

Курск (4712)77-13-04

Липецк (4742)52-20-81

Магнитогорск (3519)55-03-13

Москва (495)268-04-70

Мурманск (8152)59-64-93

Набережные Челны (8552)20-53-41

Нижний Новгород (831)429-08-12

Новокузнецк (3843)20-46-81

Новосибирск (383)227-86-73

Орел (4862)44-53-42

Оренбург (3532)37-68-04

Пенза (8412)22-31-16

Пермь (342)205-81-47

Ростов-на-Дону (863)308-18-15

Рязань (4912)46-61-64

Самара (846)206-03-16

Санкт-Петербург (812)309-46-40

Саратов (845)249-38-78

Смоленск (4812)29-41-54

Сочи (862)225-72-31

Ставрополь (8652)20-65-13

Тверь (4822)63-31-35

Томск (3822)98-41-53

Тула (4872)74-02-29

Тюмень (3452)66-21-18

Ульяновск (8422)24-23-59

Уфа (347)229-48-12

Челябинск (351)202-03-61

Череповец (8202)49-02-64

Ярославль (4852)69-52-93

сайт: www.ciat.nt-rt.ru | эл. почта: cta@nt-rt.ru



Split-system cooling units and heat pumps



Outdoor unit: SP



Indoor unit: CP



Cooling capacity: 19,6 to 79,8 kW
 Heating capacity: 22,0 to 87,2 kW

Scroll compressors

R-410A refrigerant

Configuration flexibility

Outdoor centrifugal fan

Plug-fan with EC-HEE motor (optional)

DESCRIPTION

The **AirDuo Nexia** cooling units and heat pumps feature units with a split-system construction with components optimised for the refrigerant R-410A.

They are presented in two different elements:

- An outdoor unit (RSP/ISP series) equipped with centrifugal fan, hermetic scroll-type compressor and electric panel with electronic control.
- An indoor unit or air-conditioning unit (RCP/ICP series) equipped with centrifugal fan and expansion valve.

A vast number of options meet numerous operating demands.

All of the units are tested and checked in the factory.

SERIES

Outdoor unit

RSP series: Outdoor unit **cooling-only** air-condensed, designed for installation indoors or outdoors.

ISP series: Outdoor air-air reversible **heat pump** unit, designed for installation indoors or outdoors.

Indoor unit

RCP series: Indoor unit **cooling-only** with vertical construction, designed for installation indoors, connected to a network of ducts.

ICP series: Indoor unit **heat pump** reversible with vertical construction, designed for installation indoors, connected to a network of ducts.

RANGE

	1 cooling circuit compressor					2 cooling circuits 2 compressors				
SP	90	100	120	160	182	200	240	280	320	360
CP	90	100	120	160	182	200	240	280	320	360
	-	-	-	-	-	2 x 100	2 x 120	-	2 x 160	2 x 182

OPERATING LIMITS

Inlet air conditions		Cooling	Heating
Indoor coil	Minimum	14 °C WB	10 °C
	Maximum	22 °C WB	27 °C
Outdoor coil	Minimum	12 °C ①	-10 °C WB
	Maximum	48 °C	15 °C WB

① With control of condensation pressure activated up to -10°C.

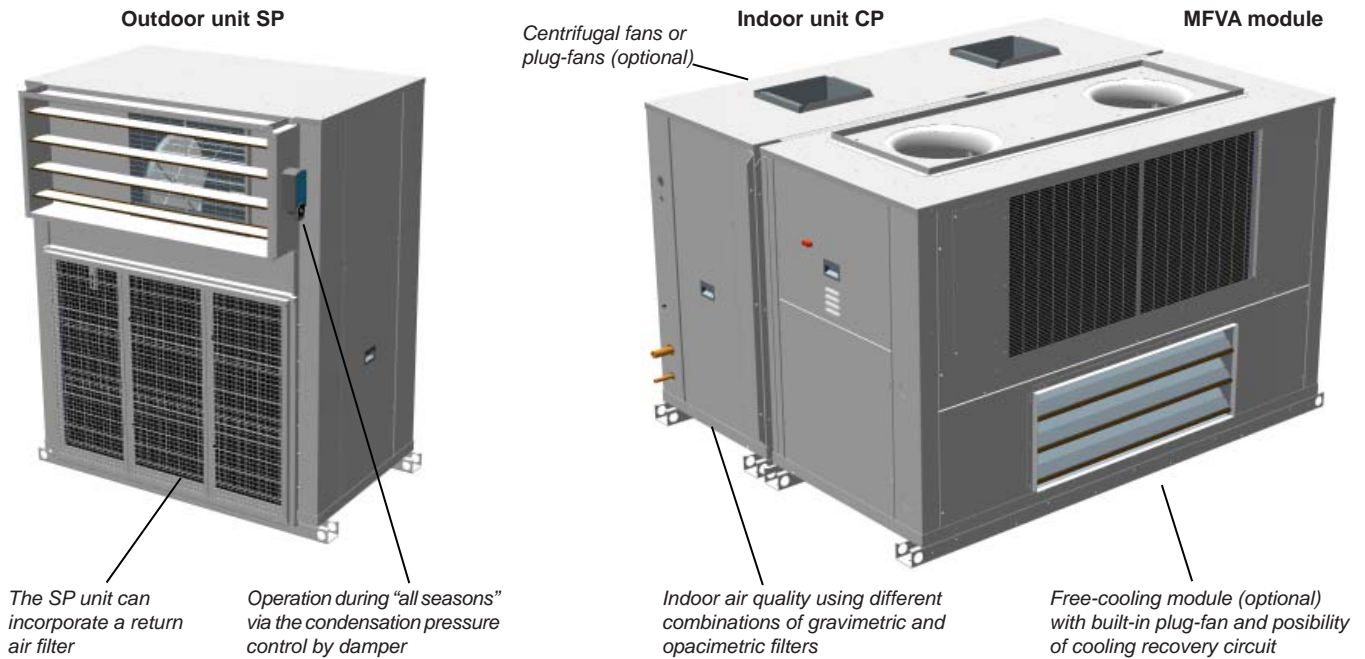

UNIT COMPONENTS

Outdoor unit SP

- Casing made of galvanised steel metal with polyester paint, white colour RAL 7035. Self-supporting frame.

Outdoor air circuit

- Centrifugal fan coupling by pulleys and belts. Electric motor(s) with tensioner, class F, IP55 and internal thermal protection. One double-intake turbine, with an impeller with front-curved blades. Greased spherical bearings, with no maintenance required.
- Coil(s) with copper pipes and aluminium fins.
- Condensates drain pan.

Cooling circuit

- Hermetic scroll-type compressor(s), assembled over antivibration mounts. Control of phase equilibrium and the direction of rotation.
- Crankcase heater.
- Thermostatic expansion valve with external equalisation (heat pump units).
- Four-way cycle reversing valves (heat pump units).
- Particle separator(s), anti-acid dehydrating filter(s), liquid receiver(s).
- Cooling connections for welding.
- Maximum equivalent length of the cooling line 50 metres (for longer distances an oil separator must be used).

Electric panel

- Complete and fully wired electric panel. Insulated panel cover to prevent condensation. Protection IP55.
- Transformer for power supply without neutral included in the electrical panel.
- Main ground connection.
- Compressor(s) and fan(s) motor contacts.

Protections

- High and low pressure pressostats.
- Compressor discharge temperature control.
- Non-return valve built into the compressor.
- Main door switch.
- Magnetothermic protection switches for the compressor(s) power line and fans motor.
- Automatic switch in the control circuit.

Indoor unit CP

- Casing made of galvanised steel metal with polyester paint, white colour RAL 7035. Self-supporting frame.

Indoor air circuit

- Coil with copper pipes and aluminium fins.
- Centrifugal fan(s) coupling by pulleys and belts. Electric motor(s) with tensioner, class F, IP55 and internal thermal protection. Double-intake turbines, with an impeller of front-curved blades. Greased spherical bearings, with no maintenance required.
- Reusable air filters, assembled on a frame.
- Condensate drain pan.

Cooling circuit

- Thermostatic expansion valve(s) with external equalisation (check valve in ICP series).

Protections

- Main door switch.



Split-system cooling units and heat pumps

Electronic controls

AVANT / AVANT+ electronic control (standard)

Available in two versions:

- AVANT : models 90 to 182
- AVANT+ : models 200 to 360

Note: Optionally, the models 90 to 182 can incorporate the AVANT+ version.

AVANT / AVANT+ control is an electronic module with microprocessor comprised of a control board and a TCO user terminal that ensures the following functions:

- Selection of the operating mode:
 - HEATING
 - COOLING
 - AUTO *Auto*
 - DEHUMIDIFICATION
 - FAN (no icon).
- Modification of the setpoint.
- Permanent control of the operating parameters.
- View of the values measured by the sensors.
- View of the alarms produced by means of codes.
- Timing of the compressors.
- Control of the compressor discharge temperature by probe.
- Control of the ambient temperature thanks to the probe incorporated into TCO terminal. This probe can be replaced by an return or ambient probe that would be installed in the control board.
- Control of the outlet temperature to improve **thermal comfort level** of the installation.
 - In cooling mode this control prevents excessively significant drops in the ambient temperature.
 - In heating mode, it prevent the stratification of the hot air masses.
- The following features improve the energy management of the installation:



Defrosting management (in heat pump units). Possibility of **intelligent defrosting** that reduces energy consumption of the heat pump, by adjusting the time between defrosting operations to the actual needs of the unit.



Compensation of the setpoint based on the outdoor temperature. This function prevents thermal "shock" between the inside and outside of the premises whilst at the same time provides significant energy savings



Time schedule that reduces energy consumption, adjusting the needs of air conditioning of the building throughout the day. TCO terminal has a schedule programmer with an intuitive graphic interface that allows 6 time slots to be chosen for each day of the week. A change in the setpoint temperature or the disconnection of the unit can be scheduled in these time slots (according to the building occupancy).



Optional functions:

- Control of the auxiliary electrical heaters.
- Proportional control of a hot water auxiliary coil.

- Humidity control.
- Anti-fire safety.
- Control of the opening of the outdoor air damper.
- Operation during all seasons via the condensation and evaporation pressure control.
- Management of thermal free-cooling.
- Detection of clogged filters and air flow control.
- Connection to a centralised technical management system (BMS) for supervision (please see "Optional" chapter).

Optionally, this control can have a terminal for pGD1 maintenance that facilitates the initial scheduling of the unit, the modification of the operating parameters and the description of the alarms produced.



CIATrtc electronic control (optional)

Electronic module with microprocessor comprised of a control board and a pGD1 graphic terminal installed over the unit electric panel and accessed using a polycarbonate collapsible window.

Optionally this terminal can be replaced by a TCO user terminal for installation inside of the premises. In this case the TCO terminal are not allowed to access parameters control and time schedule.

The management of the ambient temperature is controlled via a NTC ambient probe. This probe can be replaced by 1 or 2 RS485 probes.



In addition to the functions described in AVANT / AVANT+ control, this control allows controlling optional elements such as:

- Cooling recovery circuit.
- Electronic plug-fans.
- Enthalpic or thermoenthalpic free-cooling.
- Smoke detecting station.
- Air quality probe for measuring CO₂ and/or volatile compounds..
- Energy meter.
- Refrigerant leak detector.

It also manages a local connection between units through a pLAN network (µPC MEDIUM Local Area Network), thus allowing communication of data and information for a maximum of 15 units. This enables the reduction of the number of pGD1 terminals, since a single shared terminal can monitor all control boards. It also allows to share the reading of some probes.

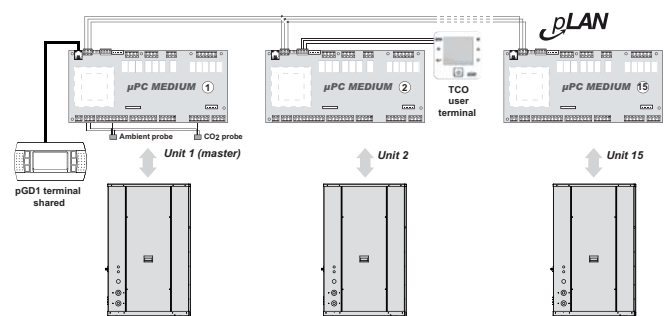

OPTIONAL

Optional for the outdoor unit SP

Outdoor environment

Temperature

- Operation during all seasons via the condensation pressure control by damper (up to -10°C).

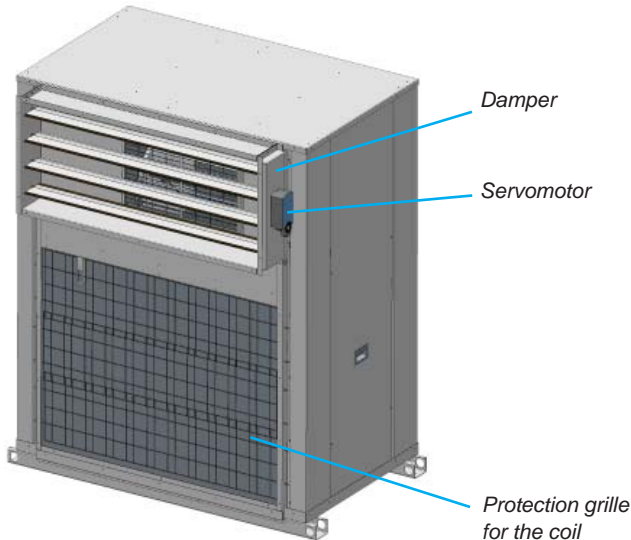

Corrosion

- Coil with copper pipes and copper fins.
- INERA® coil with copper pipes and fins of an aluminium alloy, of high performance and great resistance to the corrosion.
- Coil with copper pipes and aluminium fins with polyurethane and Blygold® coating.

Humidity

- Tropicalised electric panel.
- Tropicalised motors and fans (please consult).

Safety

- Soft starter of the supply fan which prolongs the set time mainly aimed at installations with cloth ducts.

Installation

- Antivibration mounts made of rubber.
- Service valves for cooling connections.
- Oil separator for cooling connections with maximum equivalent length of the cooling line greater than 50 metres.
- Position of air supply of the outdoor unit: side or upper.
- Different configurations of available pressure from 7 to 35 mm.w.c
- Air coil protection grille (it's not compatible with the air filter).
- Gravimetric filters in the return air. The filters frame is removable, and upon request, it is possible to supply the frame separately with the unit SP, to be joined on site (width = 53 mm)

Acoustic

- Acoustic insulating cover for compressor

Electric panel

- Electrical power supply with neutral.
- Energy meter for monitoring of the power consumption of the installation (with CIATrtc control). Available if the unit does not incorporate electrical heaters.



Optional for the indoor unit CP

Outdoor environment

Temperature

- Thermal and acoustic insulation of the casing 30 mm thick, with reaction to fire Euroclass A2-s1, d0.

Corrosion

- Coil with copper pipes and copper fins.
- INERA® coil with copper pipes and fins of an aluminium alloy, of high performance and great resistance to the corrosion (indoor unit and/or hot water coil).
- Coil with copper pipes and aluminium fins with polyurethane and Blygold® coating (indoor unit and/or hot water coil).
- Condensates drain pan in stainless steel.

Comfort / heating options

- Hot water auxiliary coil, with three-way valve, for heating in heat pump units.
If the unit includes hot water coil and free-cooling, and works with negative temperatures of outdoor air, an anti-freeze thermostat as safety system is mandatory.
- Auxiliary electrical heaters. With this option, the air flow controller is included.

Comfort / indoor air quality options

- Filtration of the supply air:
 - Gravimetric filter G4.
 - Gravimetric filter G4 + creased opacimetric filters F6 to F9.
 - Double stage of creased opacimetric filters: F6 + F7, F6 + F8 ó F7 + F9.



- Air quality probe for installation in the environment or in duct to enable measuring CO₂ and/or volatile compounds (with CIATrtc control).





Split-system cooling units and heat pumps

Safety

- Soft starter of the supply and/or return centrifugal fans which prolongs the set time mainly aimed at installations with cloth ducts.
- Differential pressostat for the detection of clogged filters.
- Differential pressostat for control of air flow.
- Smoke detecting station in accordance with the NF S 61-961 standard.
- Refrigerant leak detector (with CIATrtc control). This allows prompt identification of gas leaks, guaranteeing the safety of any people in the vicinity. Installation of the device ensures compliance with European standards F-GAS and EN378 as well as ASHRAE 15.



Installation

- Antivibration mounts made of rubber.
- **Compatibility 2 x 1**: two indoor units: CP and one outdoor unit: SP (models 200 to 360).
 - Two indoor units can be operated:
 - * simultaneously, with a single control and a single terminal.
 - * separately, each unit with its control and its own terminal.
 - * two indoor units can be operated separately, each unit with its control board but with a single terminal (only with CIATrtc control and pLAN network).
 - The option of simultaneous operation is not possible for indoor units with supply plug-fan or mixing box.

Compatibility 2 x 1	Models			
Outdoor unit: SP	200	240	320	360
Indoor unit: CP	2 x 100	2 x 120	2 x 160	2 x 180

- Centrifugal supply fan with high available pressure, from 7 to 60 mm.w.c.
- Electronic plug-fan(s) in air supply and/or return (please consult optional for "Energy saving/recovery").
- Position of supply and/or return of the indoor circuit air: side or upper.
- Supply plenum with punched or double deflection grille, which allows air to be discharged through either side.

Note: Upper supply of the CP unit is mandatory with this plenum.

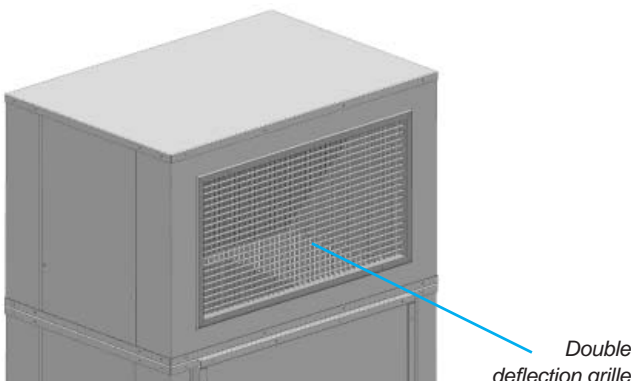

Mixing box for air renewal and free-cooling

Module separated from the unit that allows the air renewal and el free-cooling (please consult optional for "Energy saving/recovery").

It's available in two configurations:

Horizontal box (MFHA module):

- 2 motorised dampers:
- Outdoor air intake with damper, interlocked with return damper.

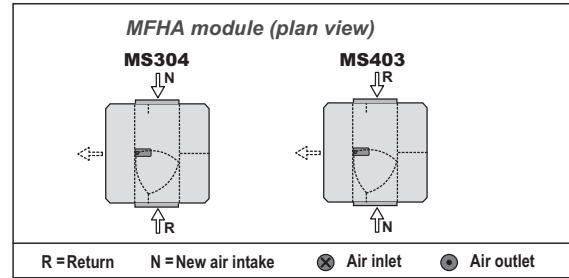

Vertical box (MFVA module) (models 182 to 360):

- 2 motorised dampers:
 - Outdoor air intake with damper, interlocked with return damper. Module: MS000.
- 3 motorised dampers:
 - Return plug-fan. Module: MC000
 - Return plug-fan and recovery circuit (please consult optional for "Energy saving/recovery"). Module: MRC000

Note: Vertical supply of the CP unit (M00 assembly) is mandatory with this box.

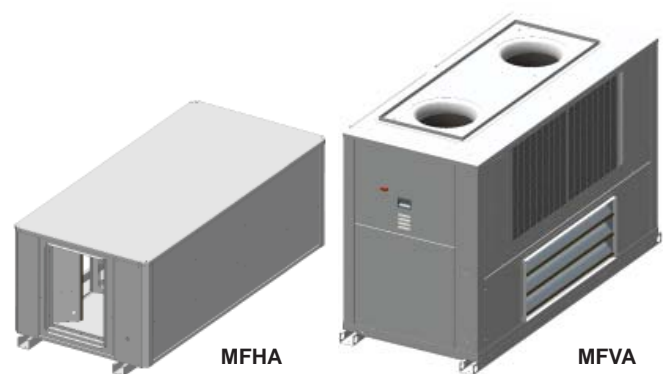
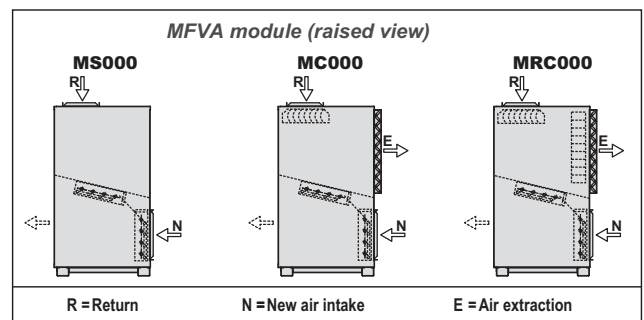

Energy saving / recovery



Free-cooling

On units with mixing box, the free-cooling can be managed by the electronic control. This function allows the outdoor air conditions to be taken advantage of when these are more favourable than those of the return (or ambient) air. As such, this allows the cooling capacity to be reduced under these circumstances. The percentage of air renewal will range from 0% to 100%.

There are three options for the free-cooling management:

- Thermal, with comparison of temperatures.
- Enthalpic, with comparison of enthalpies.
- Thermoenthalpic, with comparison of enthalpies and a correction for temperature.

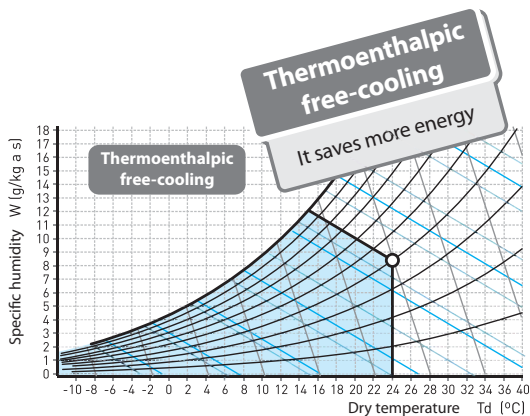
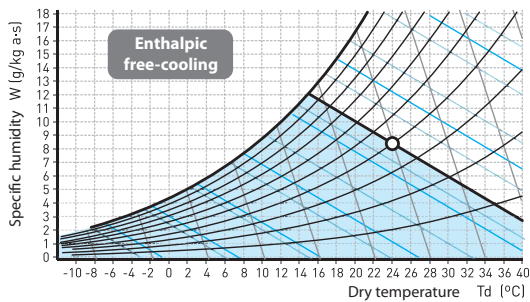
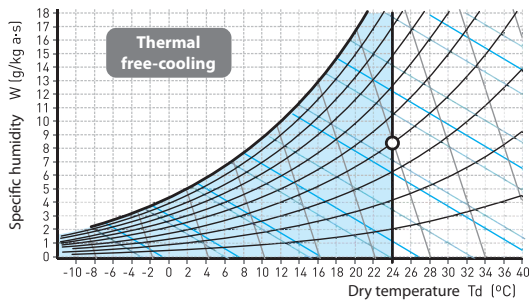

Note: With enthalpic or thermoenthalpic free-cooling change to the CIATrtc electronic control is obligatory

Active recovery (models 182 to 360)

- Circuit dedicated to recovery, with independent control, adapted to the air renewal requirements in order to raise the COP and EER of the unit set.

Note: With this option change to the CIATrtc electronic control is obligatory

The circuit is composed by:

- Plug-fan in vertical-design box with MRC000 assembly.
- Air circuit comprised of coils with copper pipes and aluminium fins.
- Thermostatic expansion valve with external equalisation.
- Hermetic scroll-type compressor with sound insulation, assembled over antivibration mounts.
- Crankcase heater.
- Four-way cycle reversing valve (heat pump units).
- Anti-acid dehydrator filter.
- Condensates drain pan.

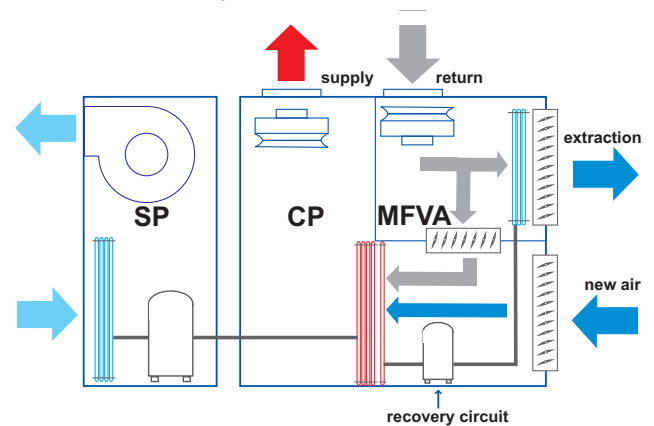

Plug-fan

- Electronic plug-fans in outlet and/or return with variable speed and flow sensor.

Note: With this option change to the CIATrtc electronic control is obligatory.

- Facilities type of service industries consumption of fans associated with air transportation assumes a high % of the annual consumption of air conditioning. The use of fans of greater efficiency has a direct impact on the reduction of consumption. Plug-fans with variable speed have associated the following advantages:

- Elimination of friction loss of the transmission by direct link.
- Greater efficiency aerualics of the rotor (impeller jet with optimized profile), with very high available pressure.
- Greater efficiency of the motor, DC motors of permanent magnets powered by electronic switching integrated in the motor.
- Variable speed that allows to keep the outlet flow constant regardless of the degree of clogging of filters.
- Accurate measurement of flow, a section calibrated in the fan aspiration and a differential pressure sensor allow control handling flow reliably both on VAC as VAV systems.

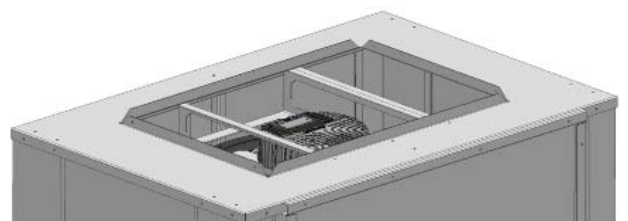

Optional for electronic controls

Control

AVANT / AVANT+ (standard)

- pGD1 terminal for maintenance of the unit.
- Kit remote control to 200 meters with pGD1 terminal (pGD1 terminal + 2 TCONN bypass cards).

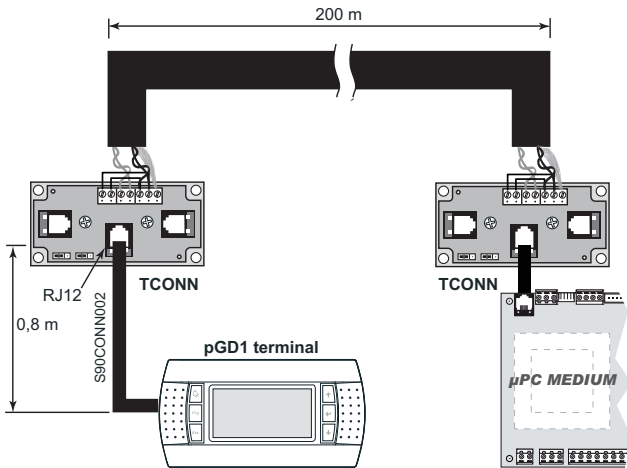

- Return or ambient temperature probe connected to the board that replaces the ambient probe of the thermostat TCO. This probe is required for anti-fire safety.
- Mixing temperature probe: compulsory to manage of the free-cooling.

CIATrtc (optional)

- TCO user terminal, instead of pGD1 terminal.
- Control without pGD1 terminal (for units with shared terminal).
- Kit remote control to 200 meters with pGD1 terminal (pGD1 terminal + 2 TCONN bypass cards).
- RS485 ambient temperature probe (optional). By default the control incorporates a NTC probe.

Note: An ambient probe with RS485 communication is required for installation to more than 30 m.

- Double ambient temperature probe with RS485 (optional).
- Ambient T+RH probe with RS485 (compulsory in units with enthalpic or thermoenthalpic free-cooling as optional). In this case also added outdoor air humidity probe.
- Air quality probe for installation in the environment or in duct to enable measuring CO₂ and/or volatile compounds.

Communication

AVANT / AVANT+ and CIATrtc controls allow the connection to a centralised technical management system by using a specific BMS card for some of the following communication protocols:

- RS485 serial cards for network communication with protocols: Carel, Modbus, LonWorks®, BACnet™ MSTP, Konnex.
- Ethernet pCO Web card for network communication with protocols: Modbus TCP/IP, BACnet™ Ethernet, TCP/IP, SNMP V1-2-3, FTP and HTTP.

Supervision solutions

Different solutions of supervision are available according to the dimensions of the installation.

• pCO Web

It is the solution for the management and supervision of a single unit if it incorporates the Ethernet pCO Web card.

• PlantWatchPRO3

It is a solution designed for the monitoring of installations of medium - small dimensions, with ability to manage up to 30 units. Suitable for technical environments, it has no parts in movement. It's available in two versions: panel and wall.

Includes: 7 " touch display, buzzer for notifications, 1 USB port and 1 SD card slot for downloading reports, charge devices models and applying service packs.

In this case, each unit needs one RS485 Carel / Modbus board.

• PlantVisorPRO2

This is the solution for the management and supervision of air-conditioning installations with up to 300 units. It performs advanced monitoring and maintenance functions and enables creating areas and groups which simplify the management of the installation. It also allows the integration of energy meters for monitoring the power consumption of the installation.

PlantVisorPRO2 is available in two versions:

- **Box:** comprised of the CPU unit and, optionally, by monitor and keyboard.
- **Touch:** this includes the CPU and the touchscreen in the one device.

In this case, each unit needs one RS485 Carel / Modbus board.

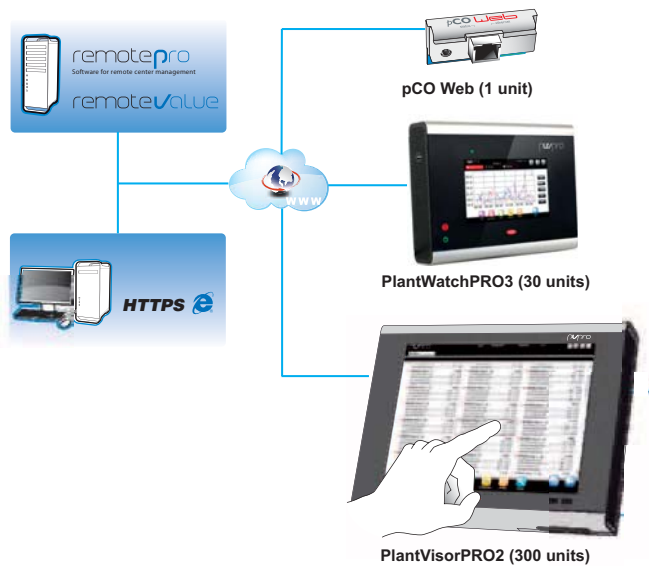

These systems allow the installation in remote management. Through a single connection to the Internet is accessed the information system. The Web interface, which is available for the local user, allows the monitoring and the complete configuration of the installation: from the office or any other user's current location.

For remote control of multiple sites, there are dedicated tools for centralized management as **RemotePRO** and **RemoteValue**.



Split-system cooling units and heat pumps

AirDuo Nexia SP-CP

TECHNICAL CHARACTERISTICS (EN-14511-2013)

SP		90	100	120	160	182	200	240	280	320	360	
Cooling capacities	Cooling capacity ① (kW)	19,6	23,2	26,7	36,4	38,9	47,0	52,9	63,8	71,8	79,8	
	Power input ③ (kW)	8,1	9,6	10,7	13,9	15,1	19,5	21,4	24,3	27,3	31,5	
	EER performance	2,43	2,41	2,50	2,62	2,57	2,41	2,47	2,63	2,63	2,53	
Heating capacities	Heating capacity ② (kW)	22,0	26,2	29,7	38,9	43,6	53,6	60,8	70,8	79,9	87,2	
	Power input ③ (kW)	7,3	9,0	10,6	13,5	14,5	18,3	20,9	23,9	27,7	30,7	
	COP performance	3,02	2,91	2,81	2,88	3,01	2,92	2,92	2,96	2,89	2,84	
Outdoor circuit centrifugal fan	Nominal air flow (m³/h)	6.500	7.000	10.000	12.200	12.200	14.000	20.000	24.400	24.400	24.400	
	Available static pressure (mm.w.c)	20										
	Number / turbines	1 / 1					2 / 2					
	Motor output (kW)	2,2	2,2	3	4	4	2 x 2,2	2 x 3	2 x 4	2 x 4	2 x 4	
	Power input (kW)	1,33	1,61	2,12	2,57	2,57	2 x 1,61	2 x 2,12	2 x 2,40	2 x 2,57	2 x 2,57	
	Speed (r.p.m.)	973	1.027	837	734	734	1.027	837	703	734	734	
Compressor	Type	Scroll										
	No. compressors / circuits / stages	1 / 1 / 1					2 / 2 / 2					
	Oil type	Copeland 3MAF 32 cST, Danfoss POE 160 SZ, ICI Emkarate RL32 CF, Mobil EAL Artic 22 CC										
	Volume of oil (l)	3,0	3,3	3,3	3,3	6,2	2 x 3,3	2 x 3,3	2 x 3,3	2 x 3,3	2 x 6,2	
Cooling connections	Circuit 1: Liquid line	1/2"	1/2"	5/8"	5/8"	5/8"	1/2"	5/8"	5/8"	5/8"	5/8"	
	Circuit 1: Gas line	7/8"	1 1/8"	1 1/8"	1 1/8"	1 1/8"	1 1/8"	1 1/8"	1 1/8"	1 1/8"	1 1/8"	
	Circuit 2: Liquid line	--	--	--	--	--	1/2"	5/8"	5/8"	5/8"	5/8"	
	Circuit 2: Gas line	--	--	--	--	--	1 1/8"	1 1/8"	1 1/8"	1 1/8"	1 1/8"	
Refrigerant	Type	R-410A										
	Global warming potential (GWP) ④	2.088										
	Load up to 7,5 m (kg)	9,7	10,4	11,2	14,1	15,3	19,9	21,6	28,1	29,8	29,1	
	Environment impact (tCO2 e)	20,3	21,7	23,4	29,4	31,9	41,6	45,1	58,7	62,2	60,8	
Electrical features	Mains voltage	400 V / III ph / 50 Hz (±10%)										
	Power supply	3 Wires + GND										
Maximum absorbed current	Compressor(s) (A)	15,3	18,5	20,1	25,1	29,1	37,0	40,2	46,0	50,2	58,2	
	Fan(s) (A)	5,0	5,0	6,9	9,0	9,0	10,0	13,8	18,0	18,0	18,0	
	Control (A)	0,9	0,9	0,9	0,9	0,9	1,8	1,8	1,8	1,8	1,8	
	Total (A)	21,2	24,4	27,9	35,0	39,0	48,8	55,8	65,8	70,0	78,0	
Dimensions	Length (mm)	1.191			1.471			2.186	2.746			
	Width (mm)	860										
	Height (mm)	1.437			1.717			1.437	1.717			
Weight (kg)	300	315	364	378	383	588	760	775	788	798		
CP		90	100	120	160	182	200	240	280	320	360	
Indoor circuit centrifugal fan	Nominal air flow (m³/h)	4.000	4.600	5.200	7.000	8.000	9.200	10.300	12.500	14.000	15.500	
	Available static pressure (mm.w.c)	15	15	15	15	15	15	20	20	20	20	
	Number / turbines	1 / 1					2 / 2					
	Motor output (kW)	1,1	1,5	2,2	2,2	2 x 1,1	2 x 1,5	2 x 2,2	2 x 2,2	2 x 2,2	2 x 3	
	Power input (kW)	0,58	0,92	1,21	1,54	2 x 0,66	2 x 0,99	2 x 1,25	2 x 1,27	2 x 1,59	2 x 1,99	
	Speed (r.p.m.)	1.076	1.132	1.199	997	1.040	1.120	1.241	984	1.020	1.064	
Max. abs. current	Fan(s) (A)	2,7	3,6	5,0	5,0	5,4	7,2	10,0	10,0	10,0	13,8	
Dimensions	Length (mm)	1.141			1.471			2.091			2.731	
	Width (mm) ⑤	859										
	Height (mm)	1.284			1.422			1.284			1.422	
Weight (kg)	166			216			290	320	320	408	410	

- ① Cooling capacity calculated in accordance with the EN-14511-2013 standard given for indoor temperature conditions 27°C (19°C WB) and 35°C outdoor temperature.
 ② Heating capacity calculated in accordance with the EN-14511-2013 standard given for indoor temperature conditions 20°C and 6°C WB outdoor temperature.
 ③ Total power input by compressors and motorised fans under nominal conditions, calculated in accordance with the EN-14511-2013 standard.
 ④ Climatic warming potential of a kilogram of fluorinated greenhouse gas in relation to a kilogram of carbon dioxide over a period of 100 years.
 ⑤ Upon request, it is possible to supply the frame of filters (146 mm) independently with the unit CP (713 mm), to be joined on site.

DIMENSIONS SCHEMES: OUTDOOR UNITS

SP - 90 and 100 with side supply (mm)

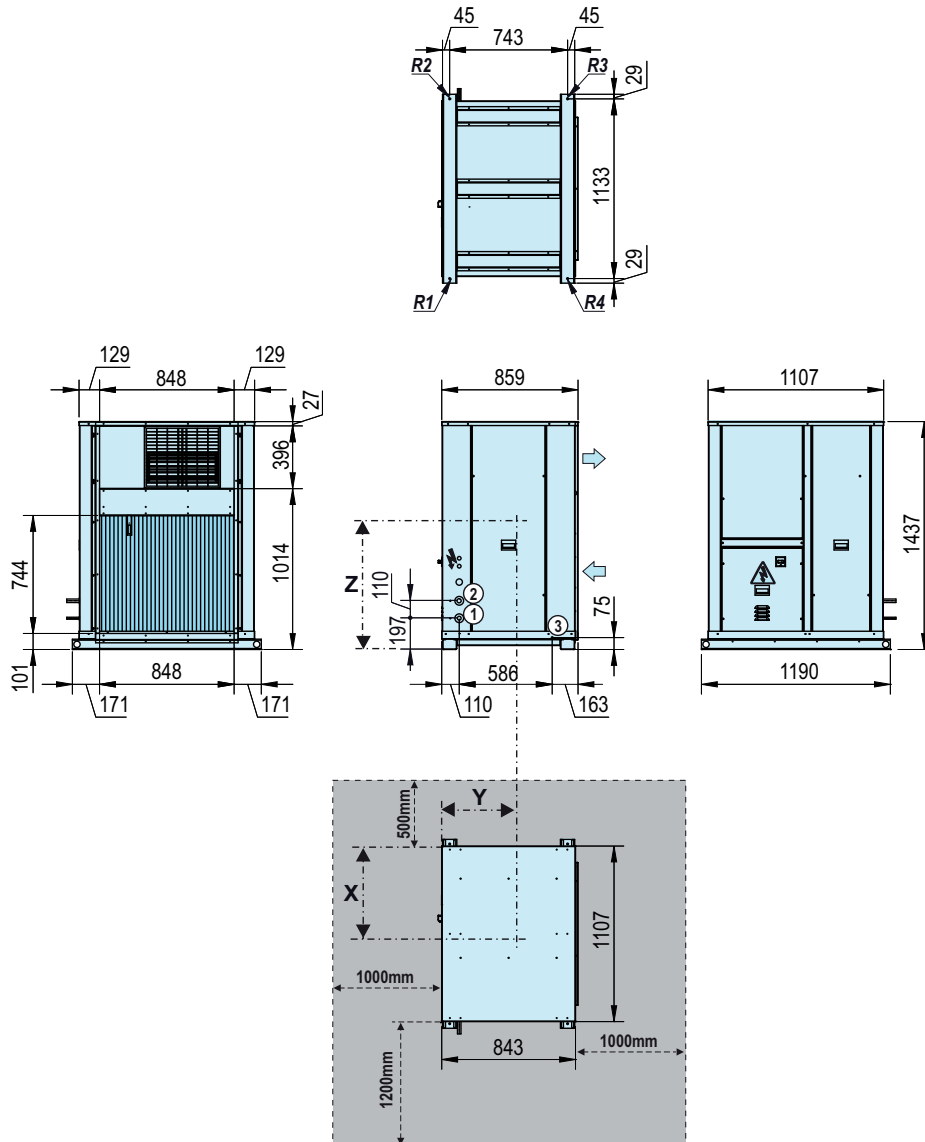

LEGEND

- Outdoor air circulation
- Electric panel
- Electric power supply
- Door switch
- ① Liquid line
- ② Gas line
- ③ Condensate outlet: trunk 7/8" M

Antivibration anchoring: rivet nut M8

Clear space to be observed for maintenance operations and unit start-up

SP	Centre of gravity (mm)			Reactions in the supports (kg)				
	X	Y	Z	Weight	R1	R2	R3	R4
90	468	404	577	300	90	67	60	83
100	468	404	577	315	94	71	63	87



Split-system cooling units and heat pumps

AirDuo Nexia SP-CP

SP - 90 and 100 with upper supply (mm)

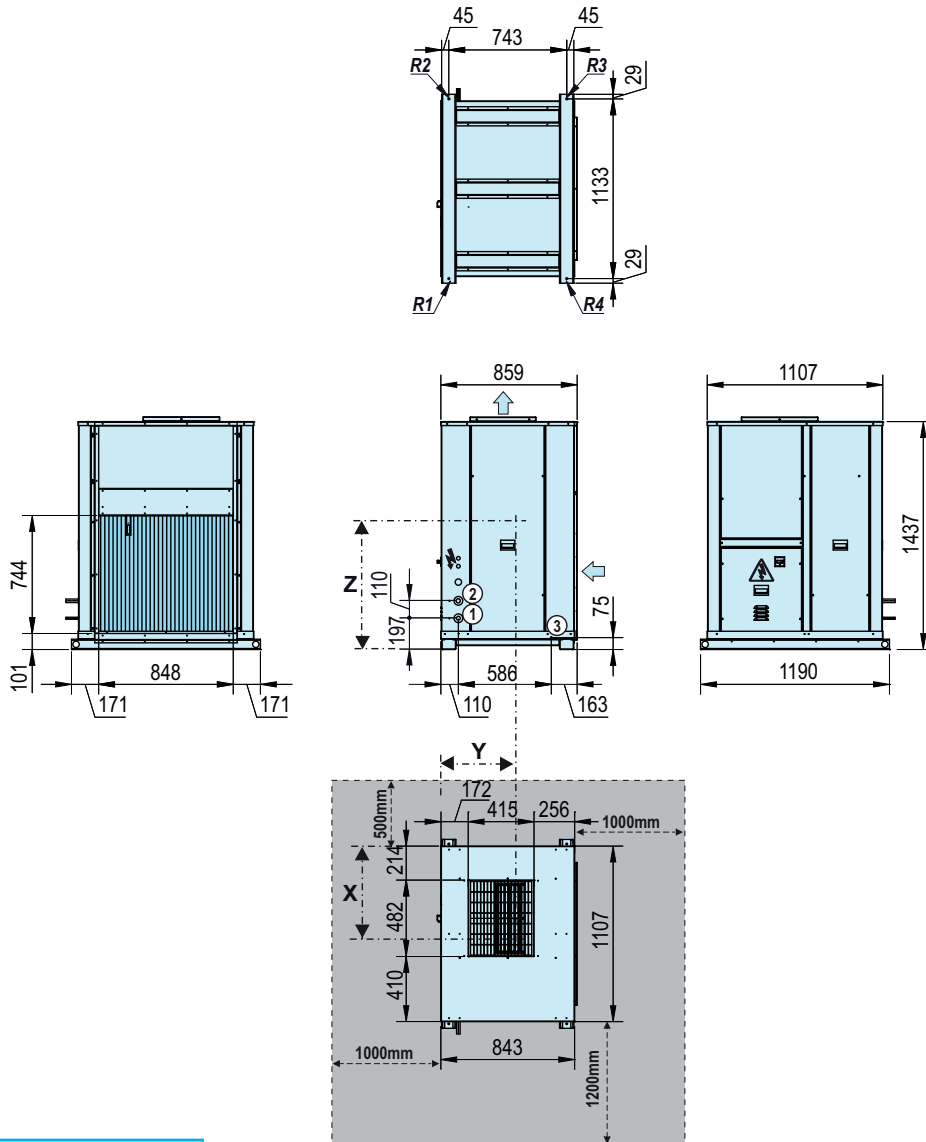

LEGEND

- Outdoor air circulation
- Electric panel
- Electric power supply
- Door switch
- ① Liquid line
- ② Gas line
- ③ Condensate outlet: trunk 7/8" M

Intake profile: 30mm

Antivibration anchoring: rivet nut M8

Clear space to be observed for maintenance operations and unit start-up

SP	Centre of gravity (mm)			Reactions in the supports (kg)				
	X	Y	Z	Weight	R1	R2	R3	R4
90	468	404	577	300	90	67	60	83
100	468	404	577	315	94	71	63	87



Split-system cooling units and heat pumps

SP - 120, 160 and 182 with side supply (mm)

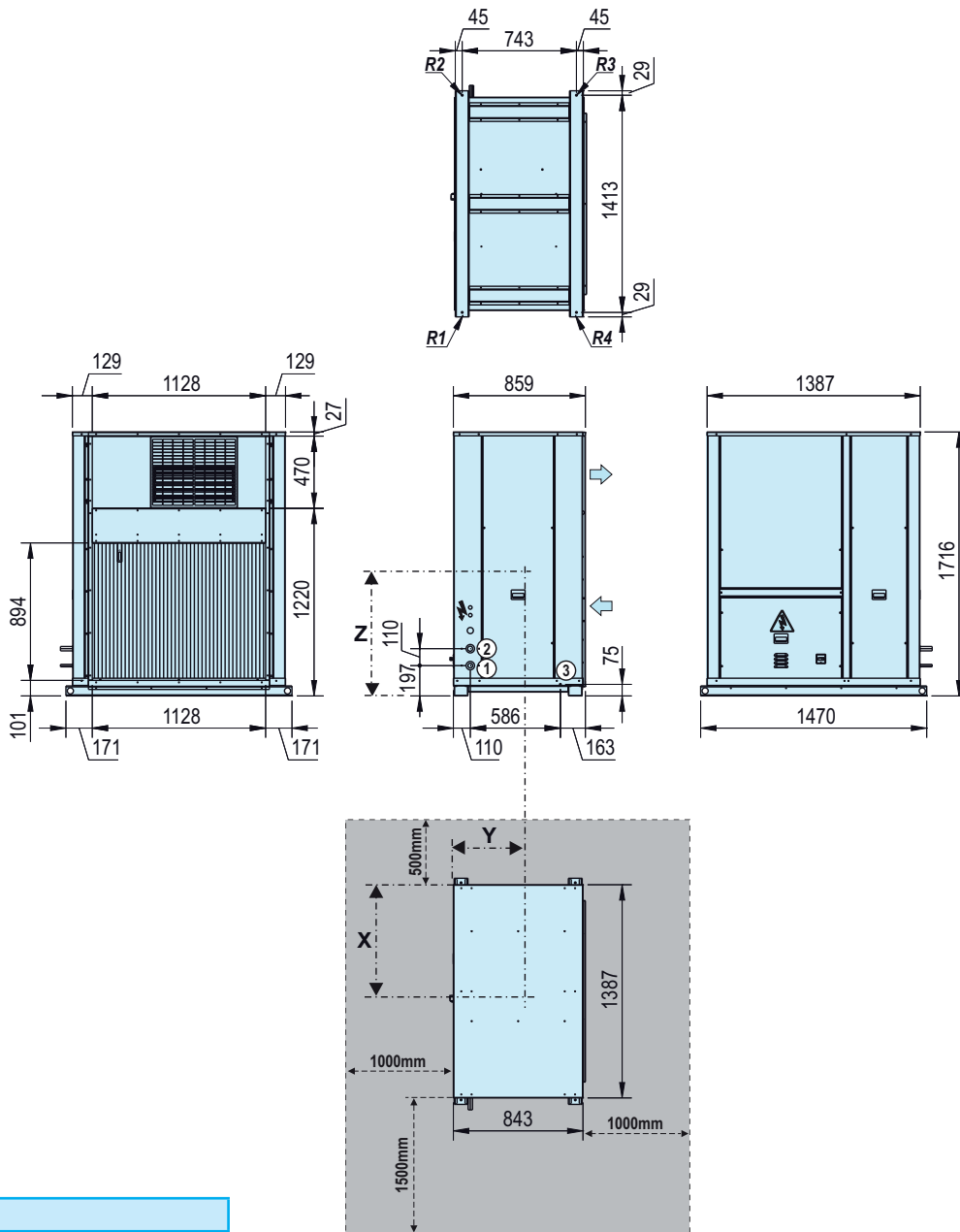

LEGEND

- Outdoor air circulation
- Electric panel
- Electric power supply
- Door switch
- ① Liquid line
- ② Gas line
- ③ Condensate outlet: trunk 7/8" M

Antivibration anchoring: rivet nut M8

Clear space to be observed for maintenance operations and unit start-up

SP	Centre of gravity (mm)			Reactions in the supports (kg)				
	X	Y	Z	Weight	R1	R2	R3	R4
120	579	410	680	364	108	79	74	103
160	579	410	680	378	113	82	76	107
182	579	410	680	383	114	83	78	108



Split-system cooling units and heat pumps

AirDuo Nexia SP-CP

SP - 120, 160 and 182 with upper supply (mm)

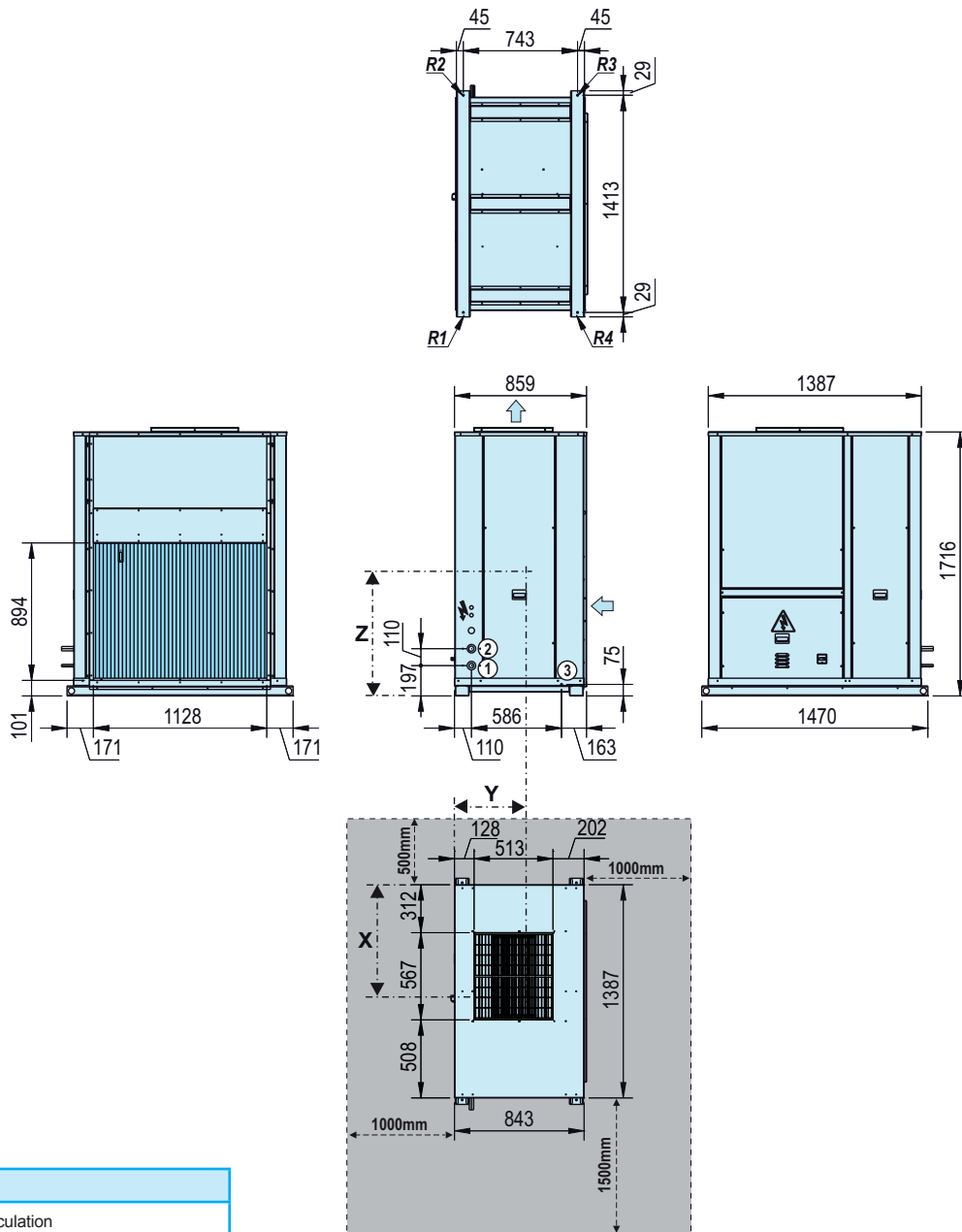

LEGEND

- Outdoor air circulation
- Electric panel
- Electric power supply
- Door switch
- ① Liquid line
- ② Gas line
- ③ Condensate outlet: trunk 7/8" M

Intake profile: 30mm

Antivibration anchoring: rivet nut M8

Clear space to be observed for maintenance operations and unit start-up

SP	Centre of gravity (mm)			Reactions in the supports (kg)				
	X	Y	Z	Weight	R1	R2	R3	R4
120	579	410	680	364	108	79	74	103
160	579	410	680	378	113	82	76	107
182	579	410	680	383	114	83	78	108



Split-system cooling units and heat pumps

SP - 200 with side supply (mm)

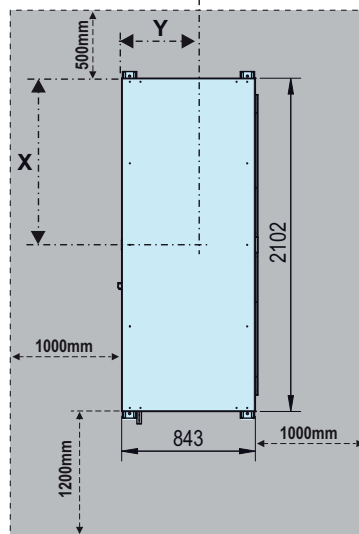
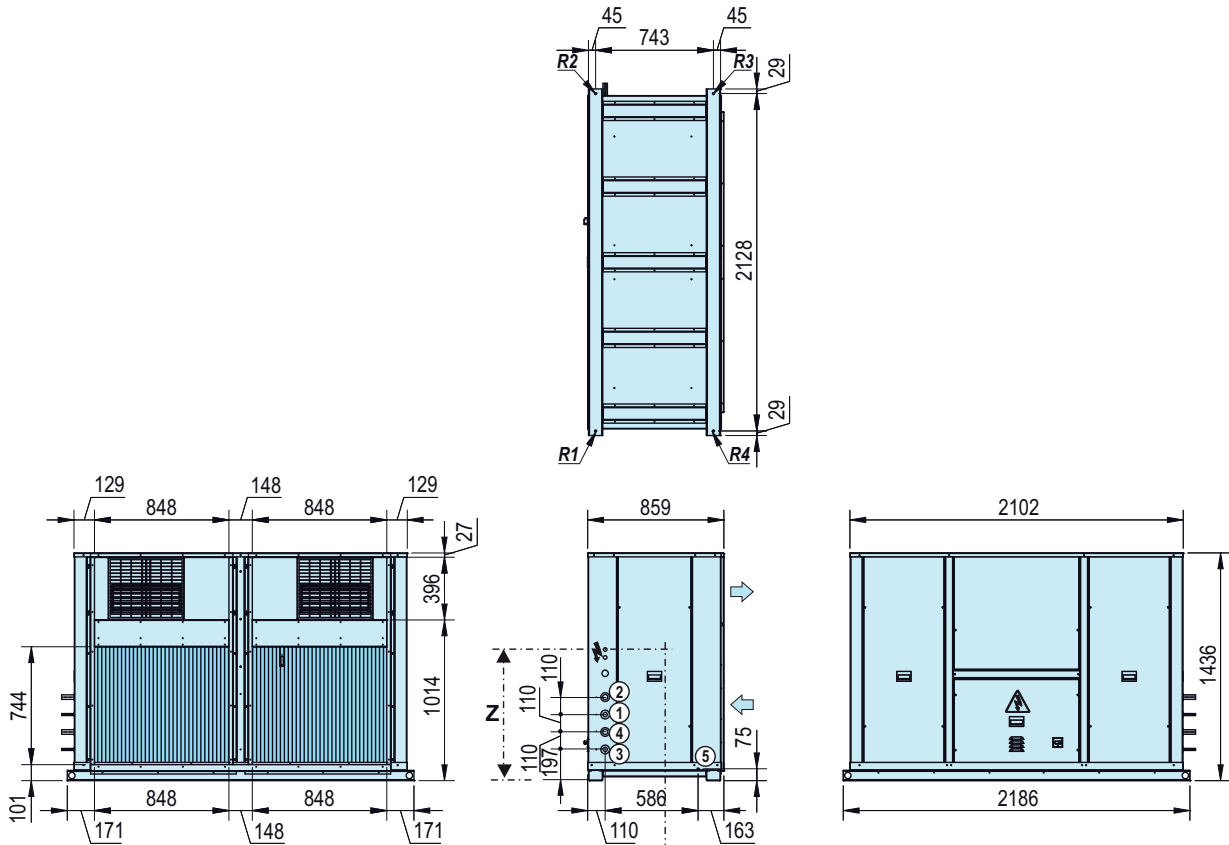

LEGEND

- Outdoor air circulation
- Electric panel
- Electric power supply
- Door switch
- ① Liquid line circuit 1
- ② Gas line circuit 1
- ③ Liquid line circuit 2
- ④ Gas line circuit 2
- ⑤ Condensate outlet: trunk 7/8" M

Intake profile: 30mm
 Antivibration anchoring: rivet nut M10

Clear space to be observed for maintenance operations and unit start-up

SP	Centre of gravity (mm)			Reactions in the supports (kg)				
	X	Y	Z	Weight	R1	R2	R3	R4
200	1055	424	577	588	145	147	149	147

SP - 200 with upper supply (mm)

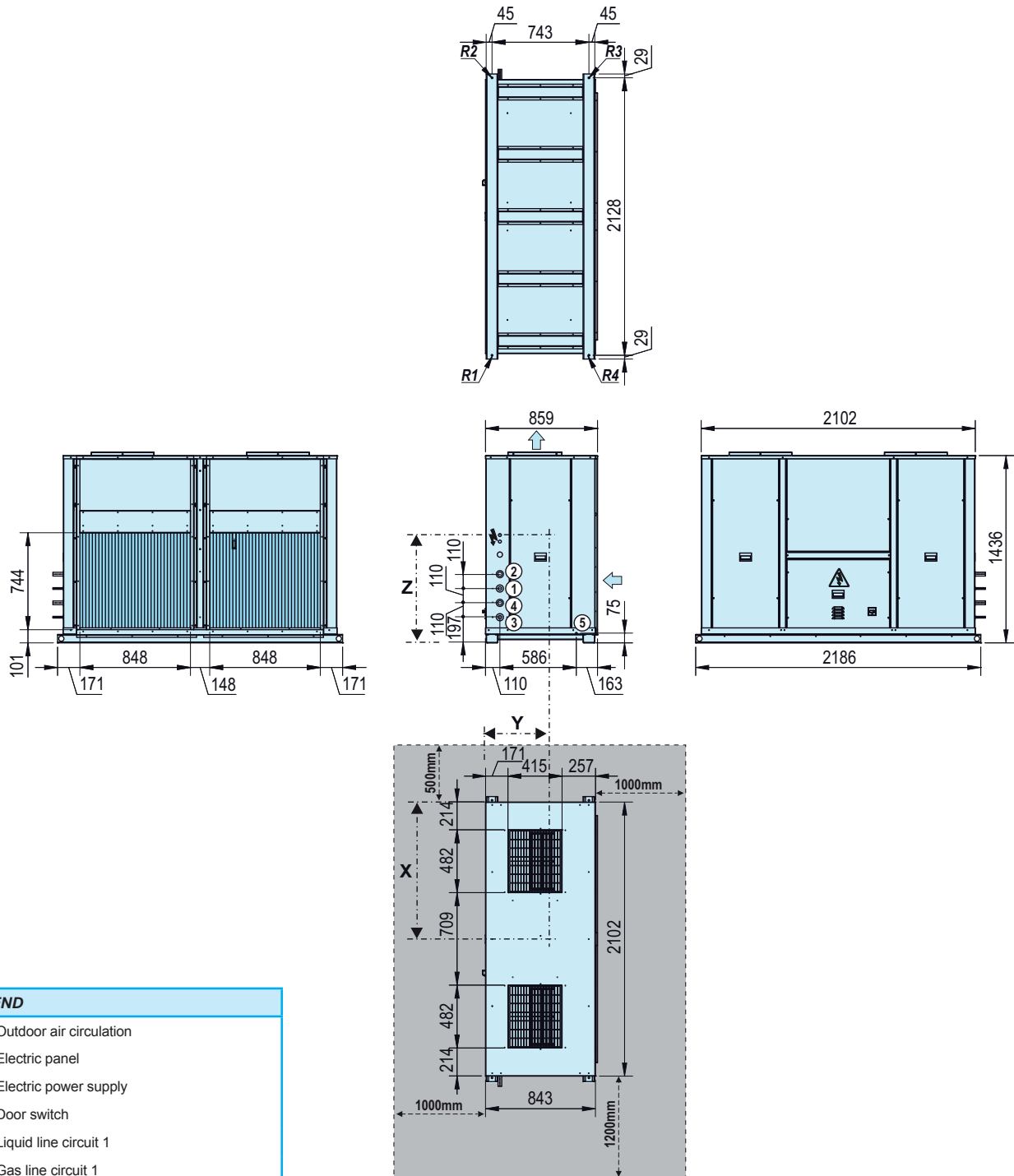

LEGEND

- Outdoor air circulation
- Electric panel
- Electric power supply
- Door switch
- ① Liquid line circuit 1
- ② Gas line circuit 1
- ③ Liquid line circuit 2
- ④ Gas line circuit 2
- ⑤ Condensate outlet: trunk 7/8" M

Intake profile: 30mm

Antivibration anchoring: rivet nut M10

Clear space to be observed for maintenance operations and unit start-up

SP	Centre of gravity (mm)			Reactions in the supports (kg)				
	X	Y	Z	Weight	R1	R2	R3	R4
200	1055	424	577	588	145	147	149	147



Split-system cooling units and heat pumps

SP - 240, 280, 320 and 360 with side supply (mm)

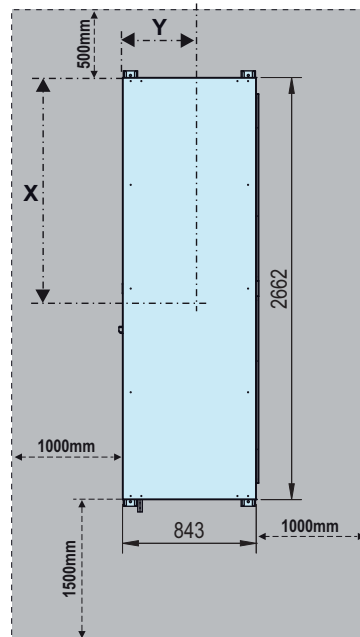
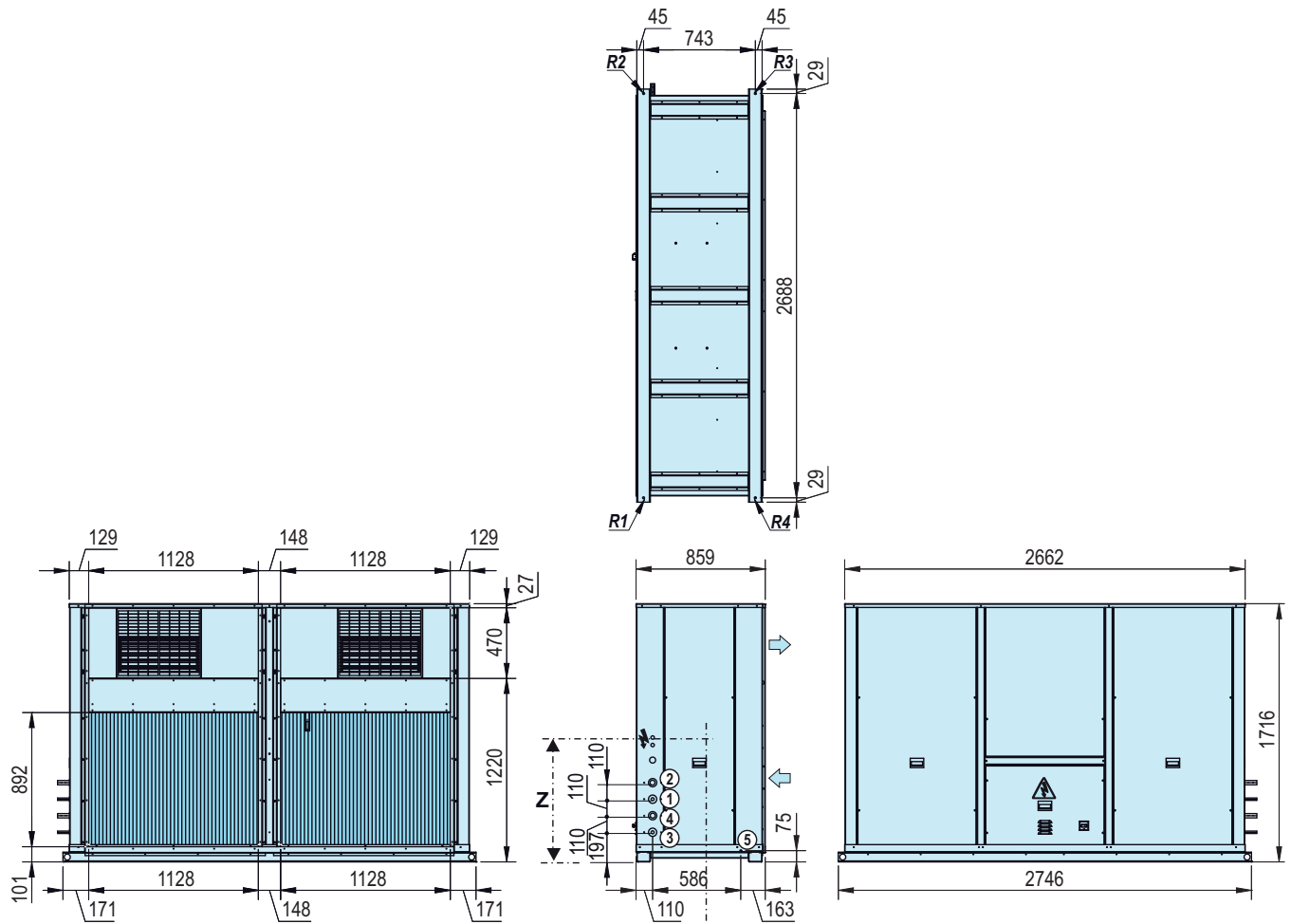

SP	Centre of gravity (mm)		
	X	Y	Z
240	1336	415	810
280	1336	415	810
320	1336	415	810
360	1336	415	810

SP	Reactions in the supports (kg)				
	Weight	R1	R2	R3	R4
240	760	193	194	187	186
280	775	196	198	191	190
320	788	200	201	194	193
360	798	202	204	197	195

LEGEND

- Outdoor air circulation
- Electric panel
- Electric power supply
- Door switch
- ① Liquid line circuit 1
- ② Gas line circuit 1
- ③ Liquid line circuit 2
- ④ Gas line circuit 2
- ⑤ Condensate outlet: trunk 7/8" M

Intake profile: 30mm
 Antivibration anchoring: rivet nut M10

Clear space to be observed for maintenance operations and unit start-up



Split-system cooling units and heat pumps

AirDuo Nexia SP-CP

SP - 240, 280, 320 and 360 with upper supply (mm)

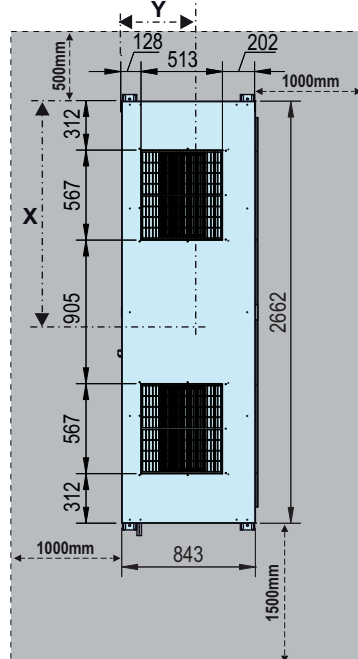
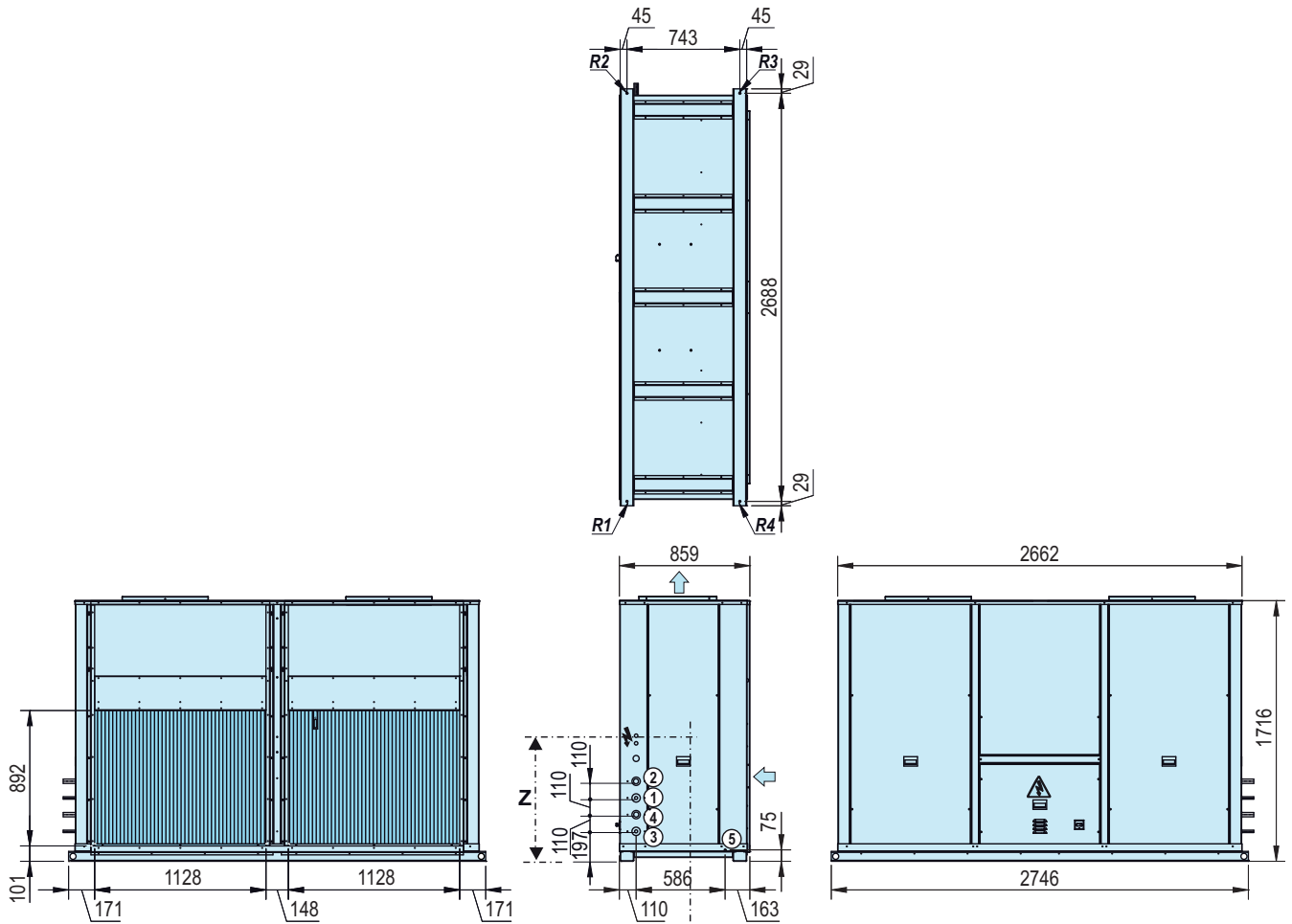

SP	Centre of gravity (mm)		
	X	Y	Z
240	1336	415	810
280	1336	415	810
320	1336	415	810
360	1336	415	810

SP	Reactions in the supports (kg)				
	Weight	R1	R2	R3	R4
240	760	193	194	187	186
280	775	196	198	191	190
320	788	200	201	194	193
360	798	202	204	197	195

LEGEND

- Outdoor air circulation
- Electric panel
- Electric power supply
- Door switch
- ① Liquid line circuit 1
- ② Gas line circuit 1
- ③ Liquid line circuit 2
- ④ Gas line circuit 2
- ⑤ Condensate outlet: trunk 7/8" M

Intake profile: 30mm
 Antivibration anchoring: rivet nut M10

Clear space to be observed for maintenance operations and unit start-up

DIMENSIONS SCHEMES: INDOOR UNITS

CP - 90, 100 and 120 with side supply (mm)

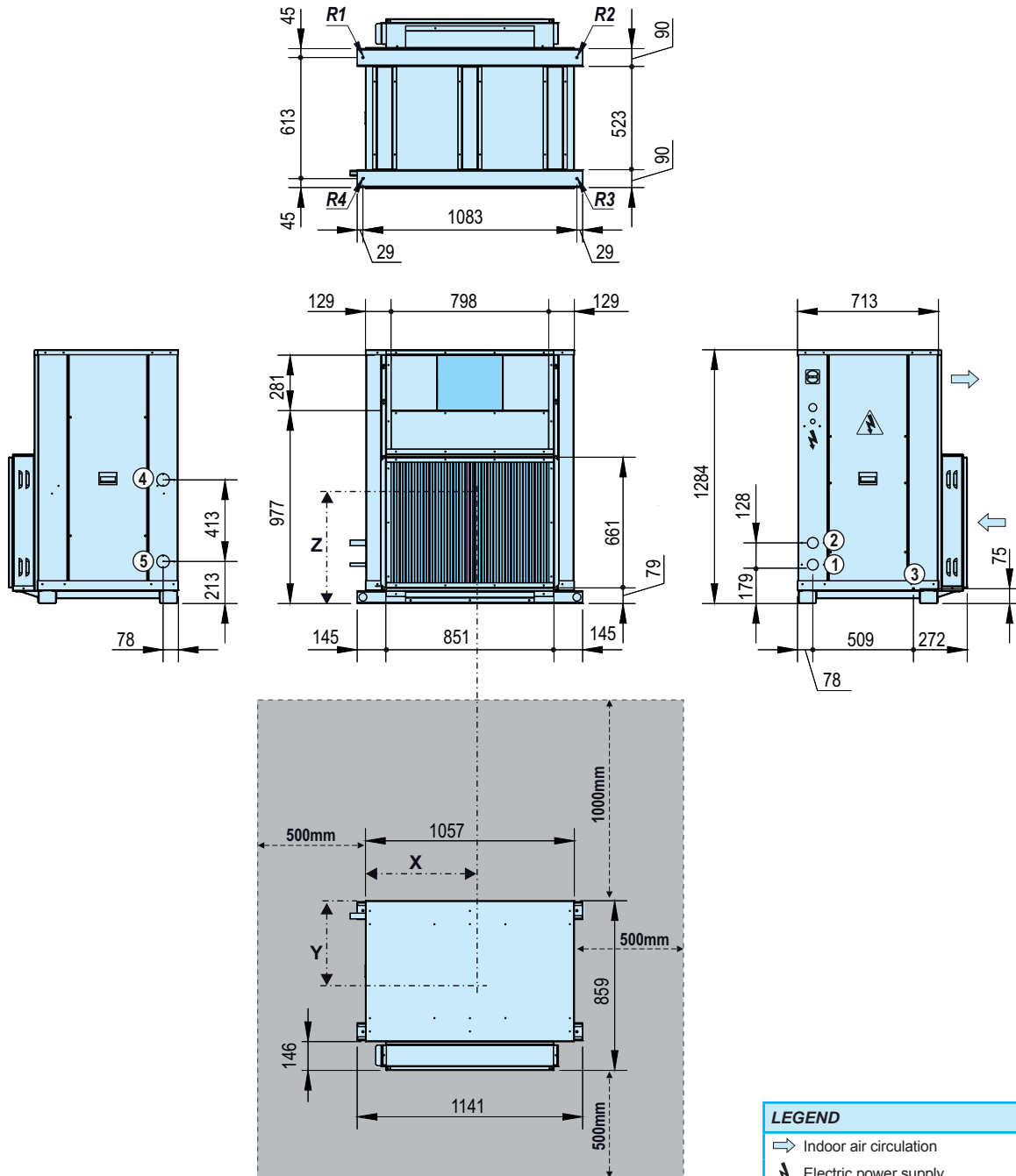

CP		Centre of gravity (mm)			Reactions in the supports (kg)				
		X	Y	Z	Weight	R1	R2	R3	R4
90	Centrifugal fan	515	408	541	174	45	36	42	51
	Plug-fan	515	408	541	174	45	36	42	51
100	Centrifugal fan	515	408	541	174	45	36	42	51
	Plug-fan	515	408	541	174	45	36	42	51
120	Centrifugal fan	515	408	541	174	45	36	42	51
	Plug-fan	515	408	541	174	45	36	42	51

LEGEND

- Indoor air circulation
- Electric power supply
- Electric panel
- Door switch
- ① Liquid line
- ② Gas line
- ③ Condensate outlet: trunk 7/8" M
- ④ Auxiliary coil water inlet (optional)
- ⑤ Auxiliary coil water outlet (optional)

Antivibration anchoring: rivet nut M8

Clear space to be observed for maintenance operations and unit start-up.
Note: provide space for the upper extraction of the air coil

CP - 90, 100 and 120 with upper supply (mm)

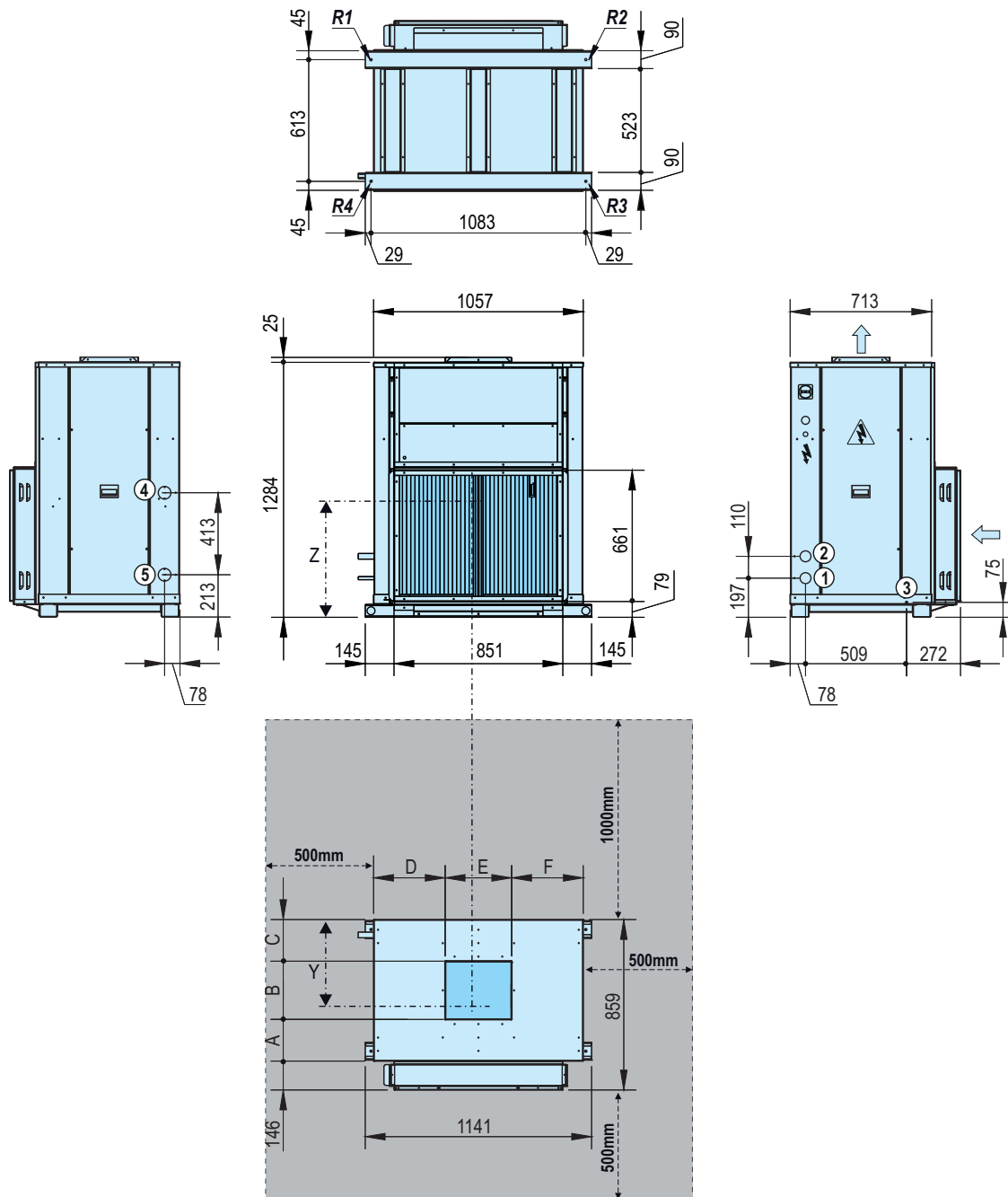

LEGEND	
	Indoor air circulation
	Electric power supply
	Electric panel
	Door switch
①	Liquid line
②	Gas line
③	Condensate outlet: trunk 7/8" M
④	Auxiliary coil water inlet (optional)
⑤	Auxiliary coil water outlet (optional)
Antivibration anchoring: rivet nut M8	
Clear space to be observed for maintenance operations and unit start-up.	
Note: provide space for the upper extraction of the air coil	

Dimensions (mm)		A	B	C	D	E	F		
Centrifugal fan		210	293	210	361	335	361		
Plug-fan		131	450	131	229	683	229		
CP	Centre of gravity (mm)			Reactions in the supports (kg)					
	X	Y	Z	Weight	R1	R2	R3	R4	
90	Centrifugal fan	515	408	541	174	45	36	42	51
	Plug-fan	515	408	541	174	45	36	42	51
100	Centrifugal fan	515	408	541	174	45	36	42	51
	Plug-fan	515	408	541	174	45	36	42	51
120	Centrifugal fan	515	408	541	174	45	36	42	51
	Plug-fan	515	408	541	174	45	36	42	51

CP - 160 with side supply (mm)

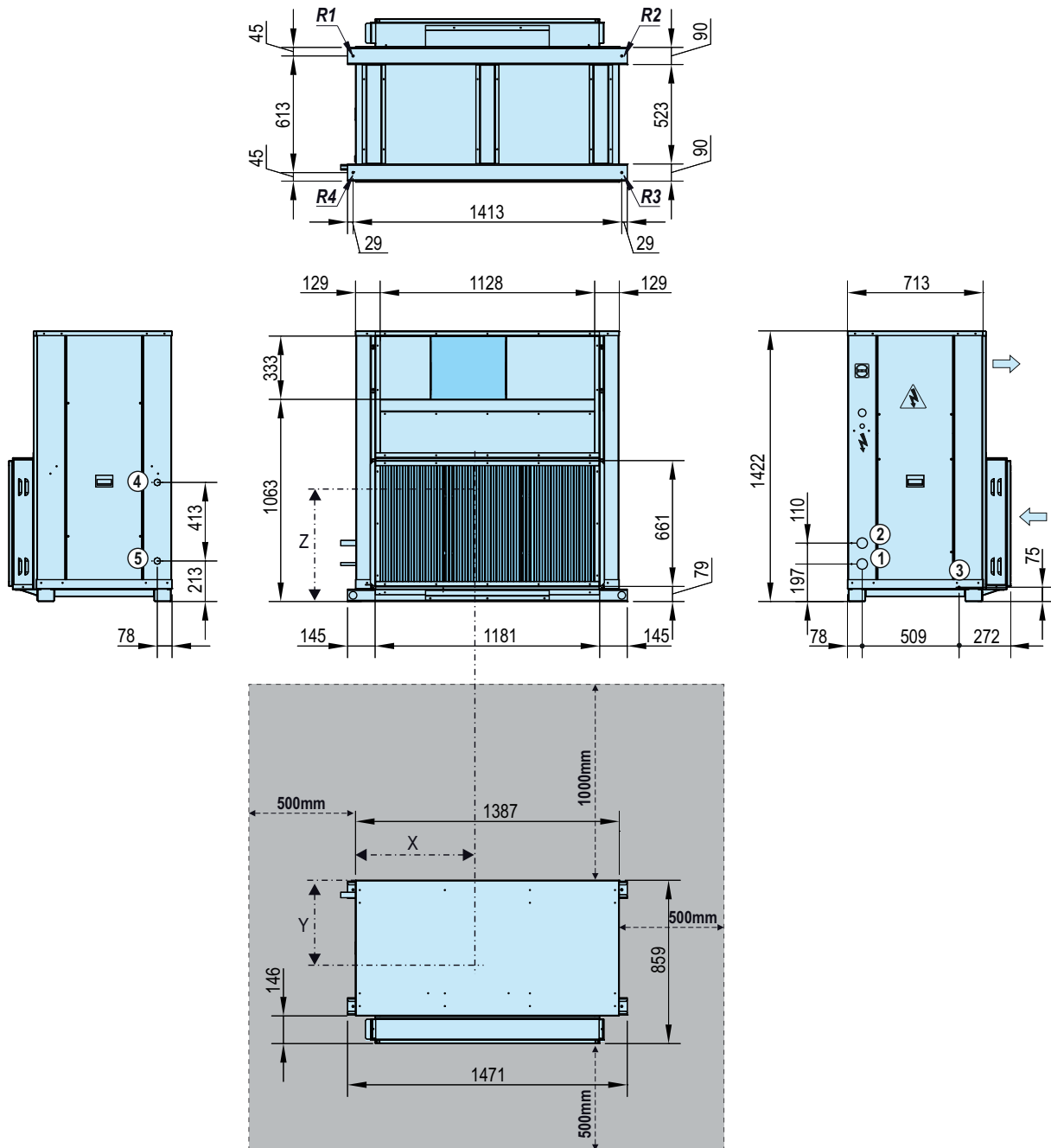

LEGEND

- Indoor air circulation
- Electric power supply
- Electric panel
- Door switch
- ① Liquid line
- ② Gas line
- ③ Condensate outlet: trunk 7/8" M
- ④ Auxiliary coil water inlet (optional)
- ⑤ Auxiliary coil water outlet (optional)

Antivibration anchoring: rivet nut M8

Clear space to be observed for maintenance operations and unit start-up.

Note: provide space for the upper extraction of the air coil

CP		Centre of gravity (mm)			Reactions in the supports (kg)				
		X	Y	Z	Weight	R1	R2	R3	R4
160	Centrifugal fan	650	241	588	227	29	15	85	99
	Plug-fan	650	241	588	215	27	14	80	93

CP - 160 with upper supply (mm)

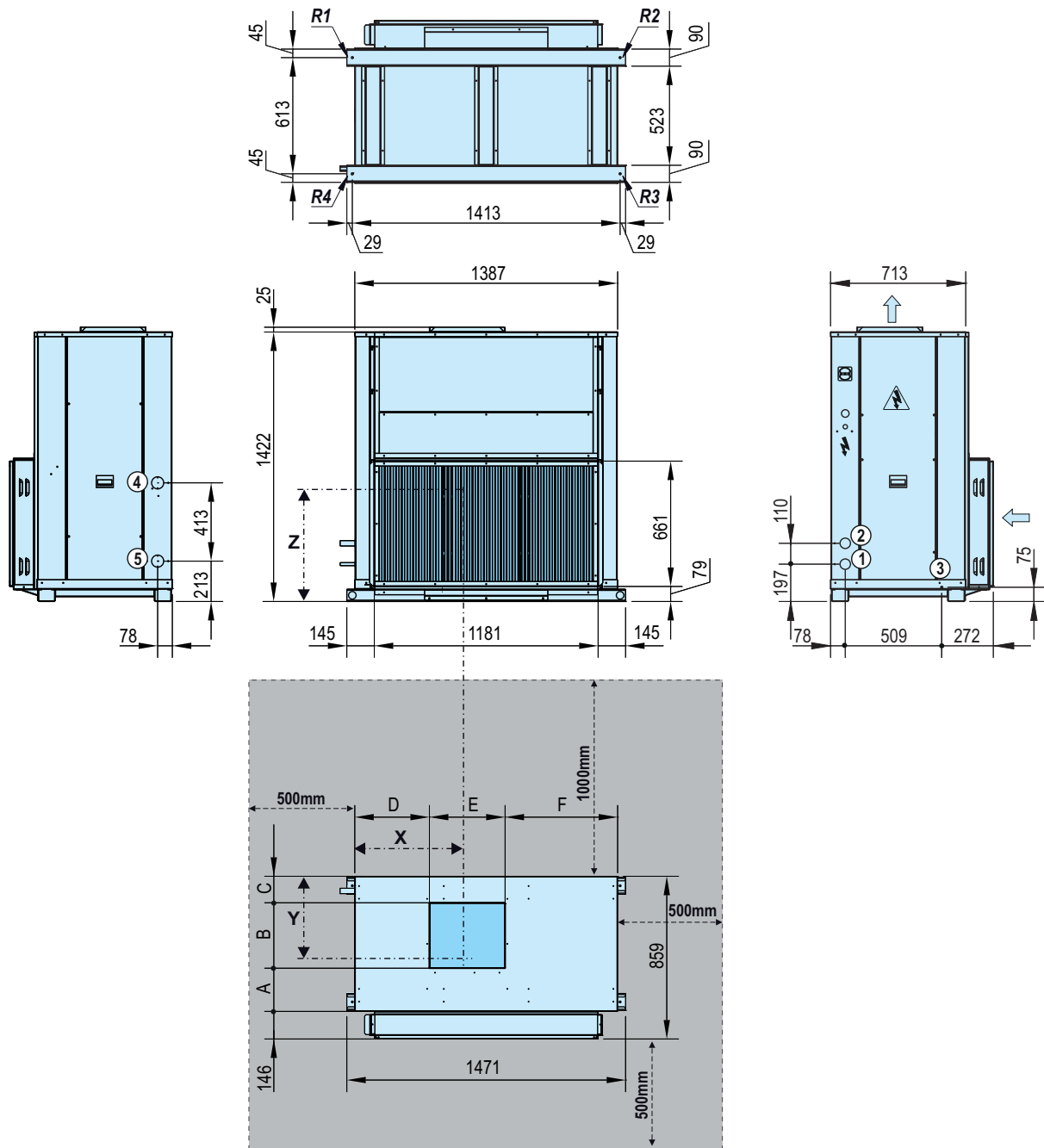

LEGEND

- ⇨ Indoor air circulation
- ⚡ Electric power supply
- ⚠ Electric panel
- 🚪 Door switch
- ① Liquid line
- ② Gas line
- ③ Condensate outlet: trunk 7/8" M
- ④ Auxiliary coil water inlet (optional)
- ⑤ Auxiliary coil water outlet (optional)

Antivibration anchoring: rivet nut M8

Clear space to be observed for maintenance operations and unit start-up.

Note: provide space for the upper extraction of the air coil

Dimensions (mm)	A	B	C	D	E	F
Centrifugal fan	228	345	140	394	399	594
Plug-fan	130	452	130	228	1015	228

CP		Centre of gravity (mm)			Reactions in the supports (kg)				
		X	Y	Z	Weight	R1	R2	R3	R4
160	Centrifugal fan	650	241	588	227	29	15	85	99
	Plug-fan	650	241	588	215	27	14	80	93



Split-system cooling units and heat pumps

CP - 182 with side supply (mm)

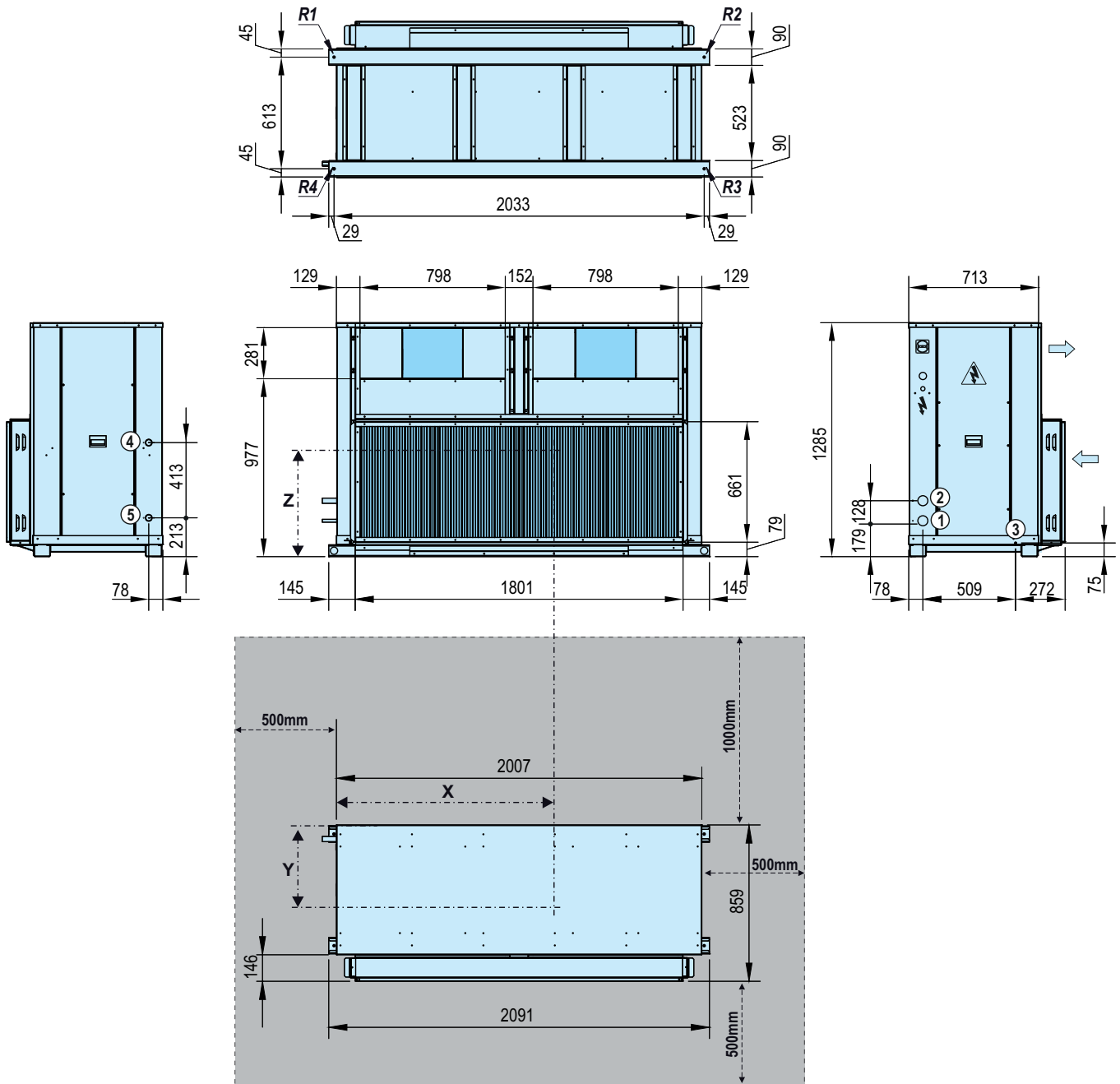

LEGEND

- ⇨ Indoor air circulation
- ⚡ Electric power supply
- ⚠ Electric panel
- ⊞ Door switch
- ① Liquid line
- ② Gas line
- ③ Condensate outlet: trunk 7/8" M
- ④ Auxiliary coil water inlet (optional)
- ⑤ Auxiliary coil water outlet (optional)

Antivibration anchoring: rivet nut M10

 Clear space to be observed for maintenance operations and unit start-up.

 Note: provide space for the upper extraction of the air coil

CP		Centre of gravity (mm)			Reactions in the supports (kg)				
		X	Y	Z	Weight	R1	R2	R3	R4
182	Centrifugal fan	989	428	537	305	80	72	72	81
	Plug-fan	989	428	537	301	79	71	71	80

CP - 182 with upper supply (mm)

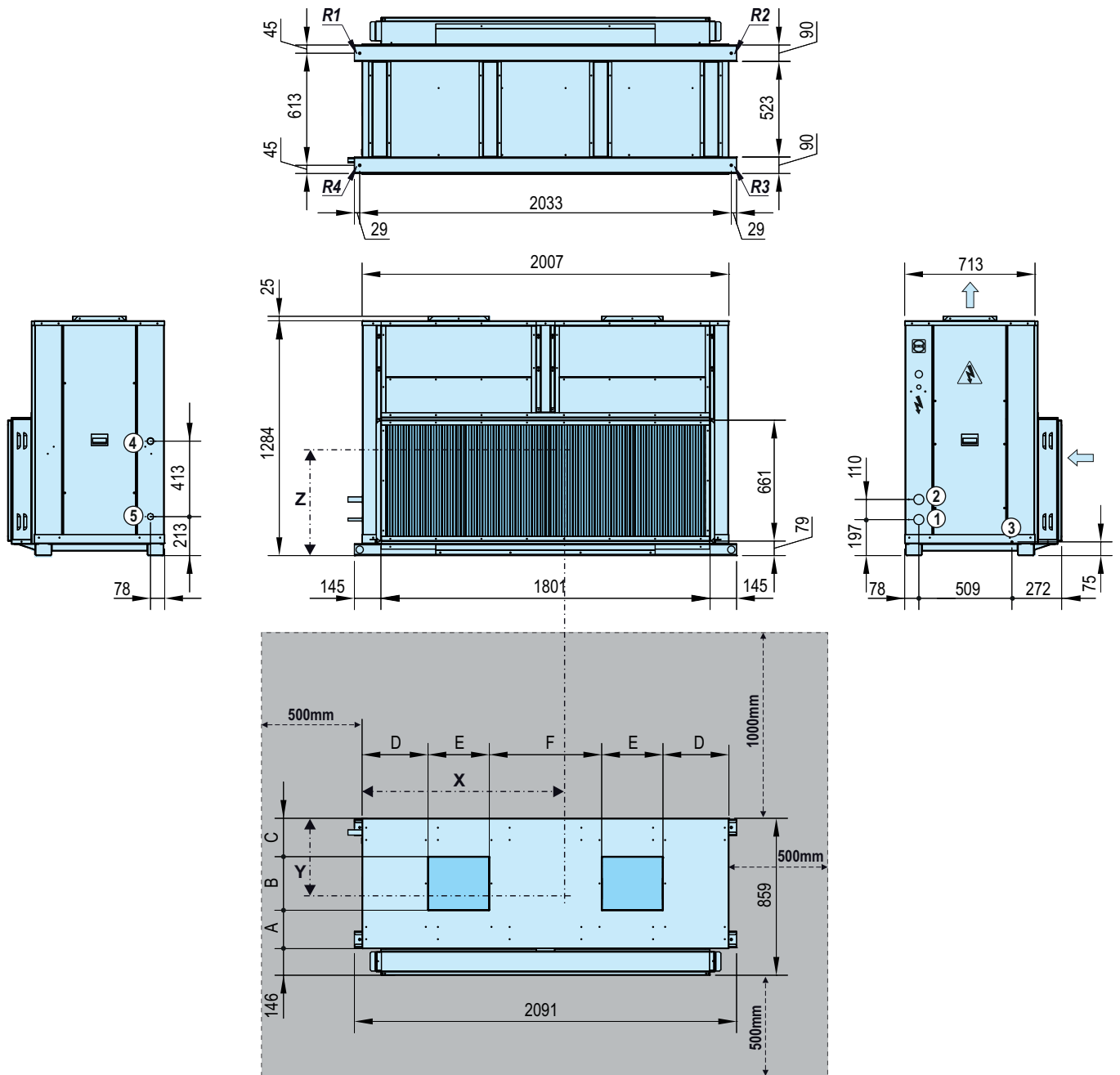

LEGEND

- ⇨ Indoor air circulation
- ⚡ Electric power supply
- ⚠ Electric panel
- 🔌 Door switch
- ① Liquid line
- ② Gas line
- ③ Condensate outlet: trunk 7/8" M
- ④ Auxiliary coil water inlet (optional)
- ⑤ Auxiliary coil water outlet (optional)

Antivibration anchoring: rivet nut M10

Clear space to be observed for maintenance operations and unit start-up.

Note: provide space for the upper extraction of the air coil

Dimensions (mm)	A	B	C	D	E	F
Centrifugal fan	210	293	210	361	335	615
Plug-fan	131	450	131	228	683	268

CP		Centre of gravity (mm)			Reactions in the supports (kg)				
		X	Y	Z	Weight	R1	R2	R3	R4
182	Centrifugal fan	989	428	537	305	80	72	72	81
	Plug-fan	989	428	537	301	79	71	71	80



Split-system cooling units and heat pumps

CP - 200 and 240 with side supply (mm)

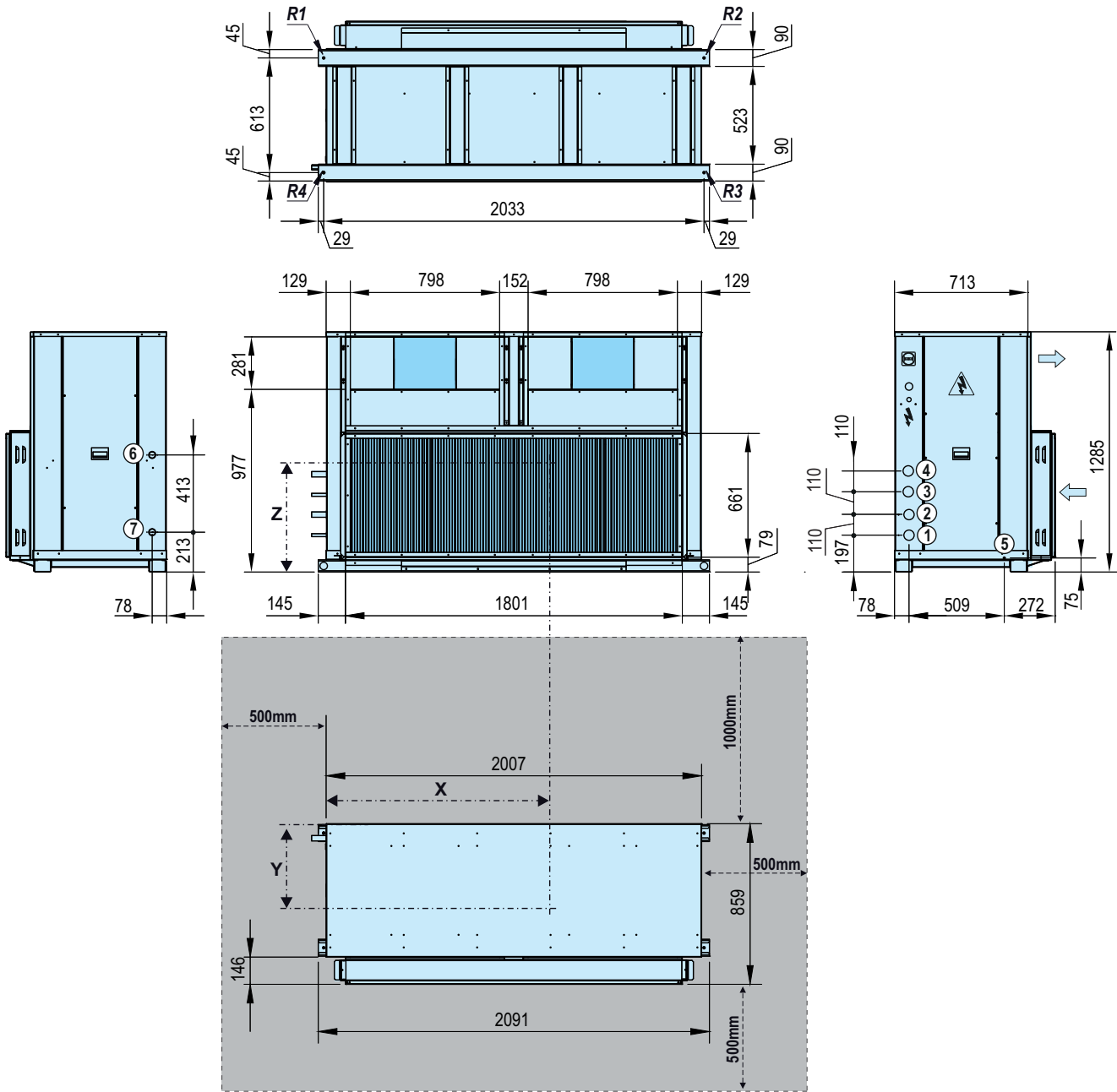

LEGEND

- ⇒ Indoor air circulation
- ⚡ Electric power supply
- ⚡ Electric panel
- ⊞ Door switch
- ① Liquid line circuit 1
- ② Gas line circuit 1
- ③ Liquid line circuit 2
- ④ Gas line circuit 2
- ⑤ Condensate outlet: trunk 7/8" M
- ⑥ Auxiliary coil water inlet (optional)
- ⑦ Auxiliary coil water outlet (optional)

Antivibration anchoring: rivet nut M10

Clear space to be observed for maintenance operations and unit start-up.

Note: provide space for the upper extraction of the air coil

CP		Centre of gravity (mm)			Reactions in the supports (kg)				
		X	Y	Z	Weight	R1	R2	R3	R4
200	Centrifugal fan	985	442	520	305	84	75	69	78
	Plug-fan	985	442	520	301	83	74	68	77
240	Centrifugal fan	985	442	520	336	92	82	76	86
	Plug-fan	985	442	520	331	91	81	74	84

CP - 200 and 240 with upper supply (mm)

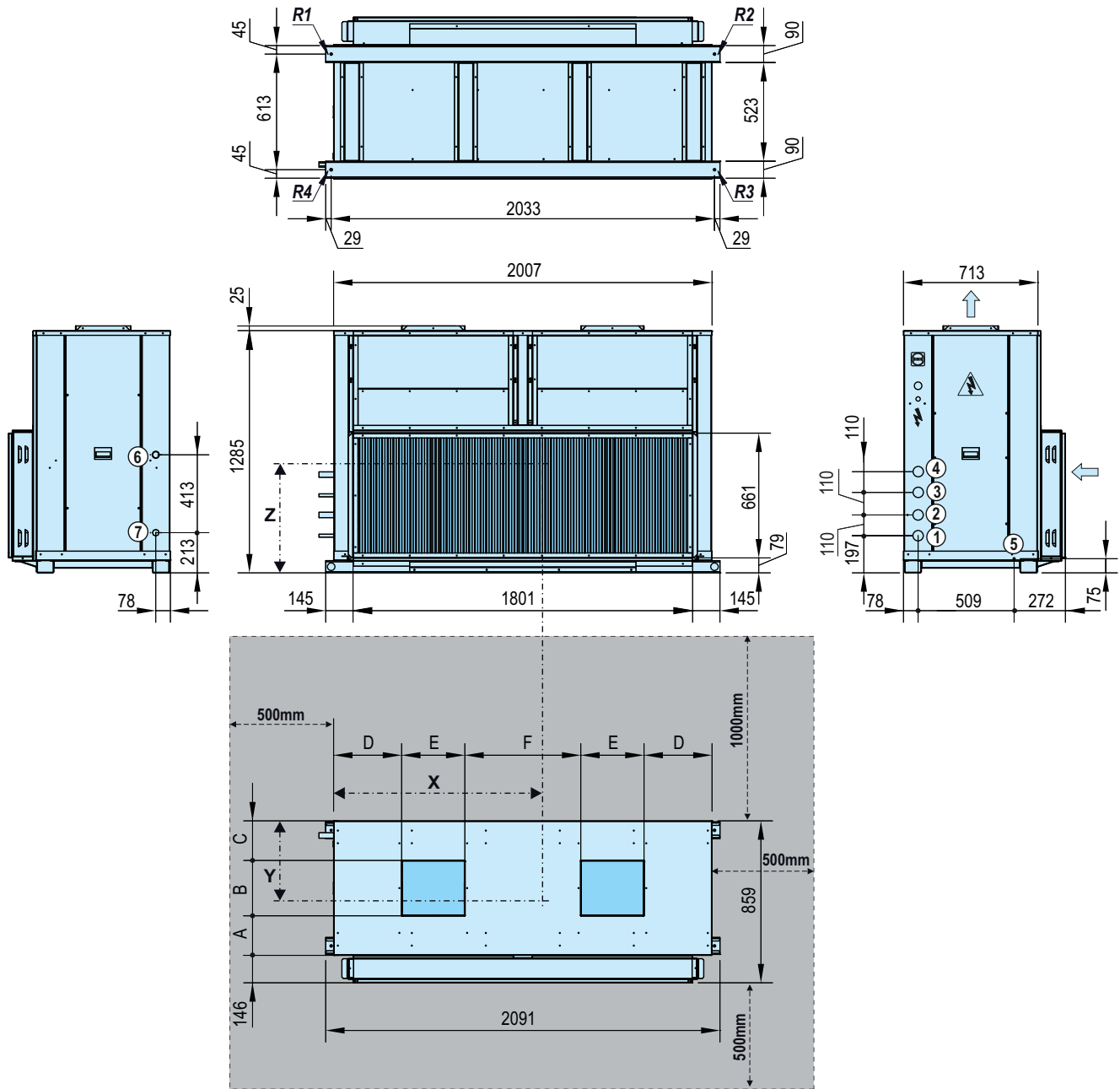

LEGEND

- Indoor air circulation
- Electric power supply
- Electric panel
- Door switch
- ① Liquid line circuit 1
- ② Gas line circuit 1
- ③ Liquid line circuit 2
- ④ Gas line circuit 2
- ⑤ Condensate outlet: trunk 7/8" M
- ⑥ Auxiliary coil water inlet (optional)
- ⑦ Auxiliary coil water outlet (optional)

Antivibration anchoring: rivet nut M10

Clear space to be observed for maintenance operations and unit start-up.

Note: provide space for the upper extraction of the air coil

Dimensions (mm)	A	B	C	D	E	F
Centrifugal fan	210	293	210	361	335	615
Plug-fan	131	450	131	228	683	268

CP		Centre of gravity (mm)			Reactions in the supports (kg)				
		X	Y	Z	Weight	R1	R2	R3	R4
200	Centrifugal fan	985	442	520	305	84	75	69	78
	Plug-fan	985	442	520	301	83	74	68	77
240	Centrifugal fan	985	442	520	336	92	82	76	86
	Plug-fan	985	442	520	331	91	81	74	84



Split-system cooling units and heat pumps

CP - 280, 320 and 360 with side supply (mm)

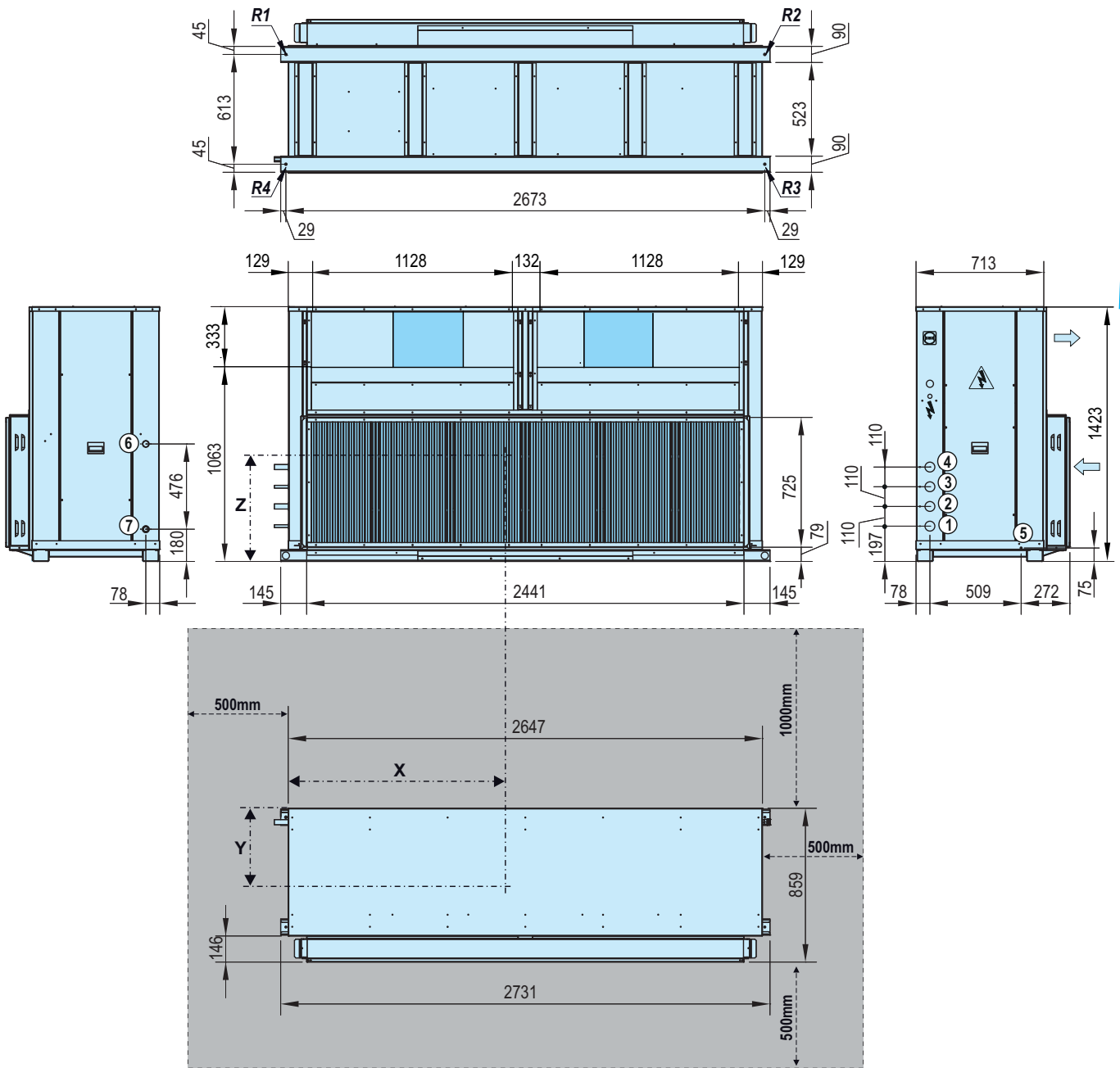

LEGEND

- ⇒ Indoor air circulation
- ⚡ Electric power supply
- ⚡ Electric panel
- ⊞ Door switch
- ① Liquid line circuit 1
- ② Gas line circuit 1
- ③ Liquid line circuit 2
- ④ Gas line circuit 2
- ⑤ Condensate outlet: trunk 7/8" M
- ⑥ Auxiliary coil water inlet (optional)
- ⑦ Auxiliary coil water outlet (optional)

Antivibration anchoring: rivet nut M10

Clear space to be observed for maintenance operations and unit start-up.

Note: provide space for the upper extraction of the air coil

CP		Centre of gravity (mm)			Reactions in the supports (kg)				
		X	Y	Z	Weight	R1	R2	R3	R4
280	Centrifugal fan	1306	428	625	428	111	102	103	112
	Plug-fan	1306	428	625	411	107	98	99	108
320	Centrifugal fan	1306	428	625	431	112	102	103	113
	Plug-fan	1306	428	625	413	107	98	99	108
360	Centrifugal fan	1306	428	625	431	112	102	103	113
	Plug-fan	1306	428	625	413	107	98	99	108

CP - 280, 320 and 360 with upper supply (mm)

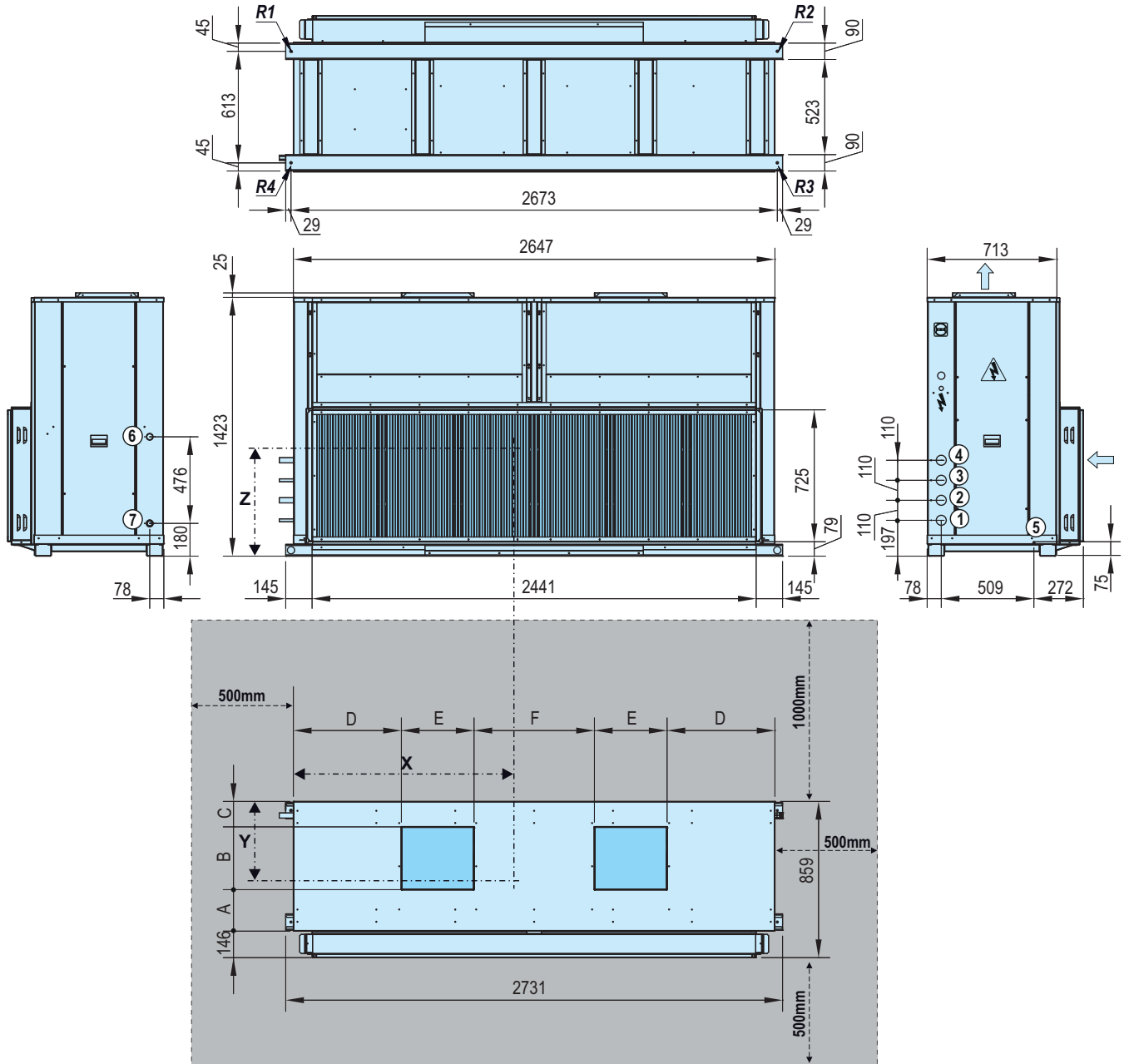

LEGEND

- ⇒ Indoor air circulation
- ⚡ Electric power supply
- ⚠ Electric panel
- Ⓜ Door switch
- ① Liquid line circuit 1
- ② Gas line circuit 1
- ③ Liquid line circuit 2
- ④ Gas line circuit 2
- ⑤ Condensate outlet: trunk 7/8" M
- ⑥ Auxiliary coil water inlet (optional)
- ⑦ Auxiliary coil water outlet (optional)

Antivibration anchoring: rivet nut M10

Clear space to be observed for maintenance operations and unit start-up.

Note: provide space for the upper extraction of the air coil

Dimensions (mm)	A	B	C	D	E	F
Centrifugal fan	228	345	140	594	399	662
Plug-fan	130	452	130	228	1015	245

CP		Centre of gravity (mm)			Reactions in the supports (kg)				
		X	Y	Z	Weight	R1	R2	R3	R4
280	Centrifugal fan	1306	428	625	428	111	102	103	112
	Plug-fan	1306	428	625	411	107	98	99	108
320	Centrifugal fan	1306	428	625	431	112	102	103	113
	Plug-fan	1306	428	625	413	107	98	99	108
360	Centrifugal fan	1306	428	625	431	112	102	103	113
	Plug-fan	1306	428	625	413	107	98	99	108

DIMENSIONS SCHEMES: ASSEMBLIES WITH MIXING BOXES (OPTIONAL)

Vertical box (MFVA module) for CP - 182, 200 and 240 (mm) (optional)

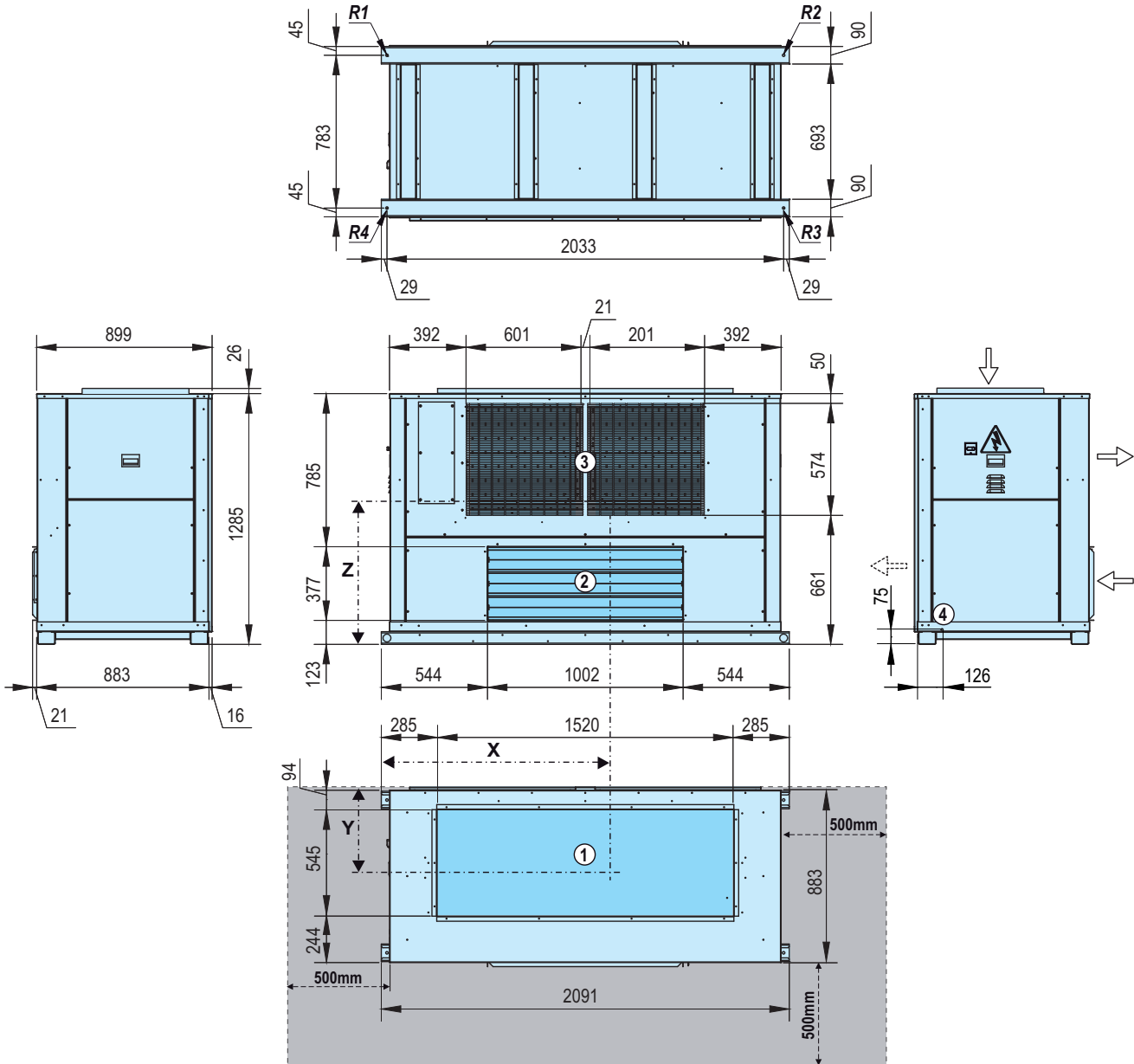

LEGEND

- Indoor circuit air circulation
- Electric panel
- Door switch
- ① Air return
- ② New air intake
- ③ Air extraction (in MC000 and MRC000)
- ④ Condensate outlet: (in MRC000); trunk 7/8" M

Antivibration anchoring: rivet nut M10

Clear space to be observed for maintenance operations and unit start-up

Note: If the CP unit has an MFVA box, the frame with the filters is located inside that box.

MFVA module	Centre of gravity (mm)			Reactions in the supports (kg)				
	X	Y	Z	Weight	R1	R2	R3	R4
182 MS000	1025	428	555	221	54	52	56	58
200 MC000	1034	425	663	292	71	69	75	77
240 MRC000	1081	405	569	367	80	86	104	97

Vertical box (MFVA module) for CP - 280, 320 and 360 (mm) (optional)

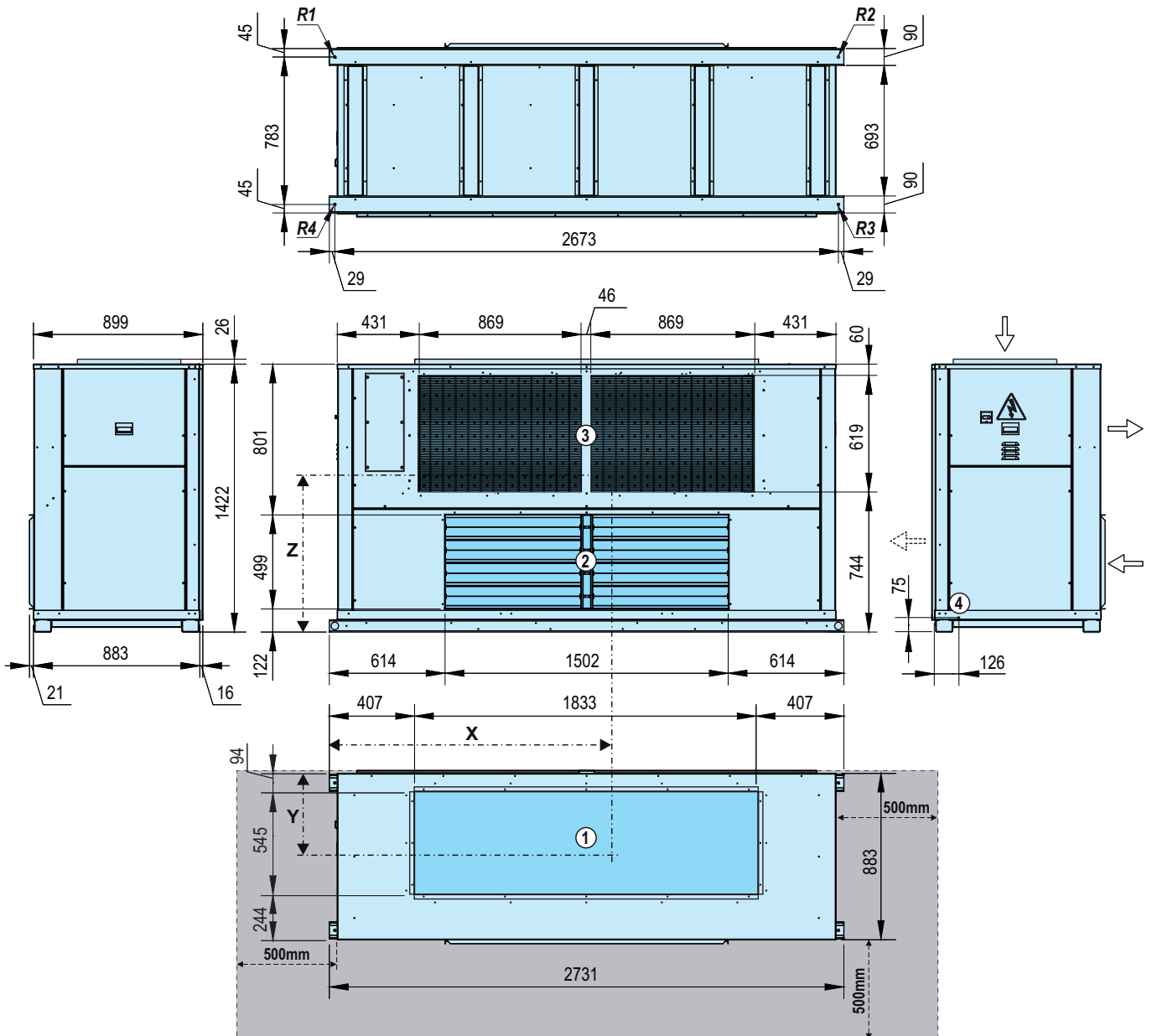

LEGEND

⇨ Indoor circuit air circulation

⚡ Electric panel

⊞ Door switch

① Air return

② New air intake

③ Air extraction (in MC000 and MRC000)

④ Condensate outlet: (in MRC000): trunk 7/8" M

Antivibration anchoring: rivet nut M10

Clear space to be observed for maintenance operations and unit start-up

Note: If the CP unit has an MFVA box, the frame with the filters is located inside that box.

MFVA module	Centre of gravity (mm)			Reactions in the supports (kg)				
	X	Y	Z	Weight	R1	R2	R3	R4
280 MS000	1327	437	607	297	76	71	73	77
320 MC000	1343	447	729	397	102	99	96	100
360 MRC000	1404	426	626	502	117	124	134	127

Horizontal box (MFHA module) for CP - 90, 100 and 120 (mm) (optional)

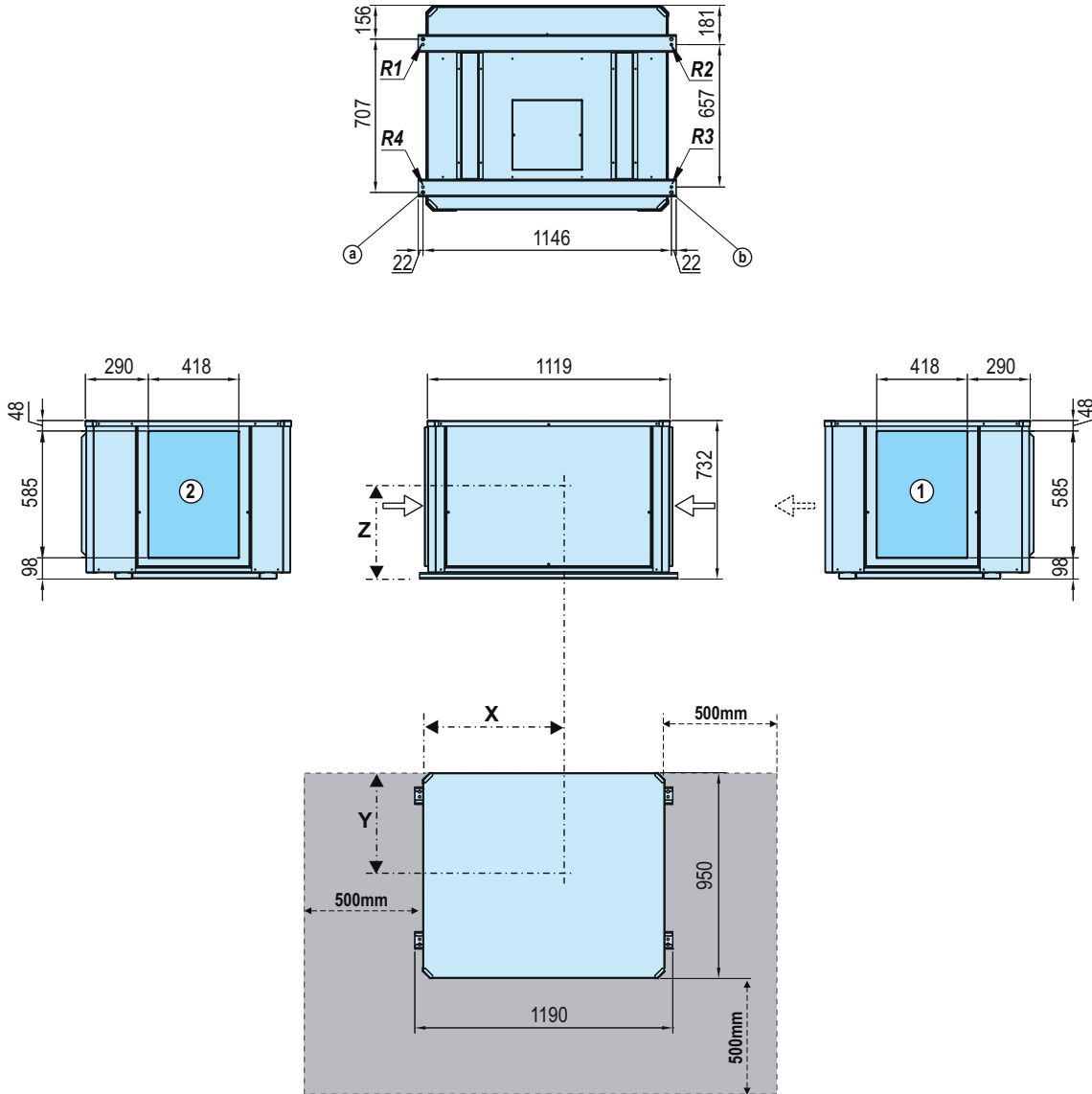

LEGEND	
	Indoor circuit air circulation
①	Return in MS304 and new air inlet in MS403
②	New air inlet in MS304 and return in MS403
a:	Antivibration anchoring: rivet nut M8
b:	Ceiling anchoring: threaded rod $\varnothing 15\text{mm}$
	Clear space to be observed for maintenance operations and unit start-up

MFHA module	Centre of gravity (mm)			Reactions in the supports (kg)					
	X	Y	Z	Weight	R1	R2	R3	R4	
90 100 120	MS304 MS403	558	459	330	98	23	23	26	26

Horizontal box (MFHA module) for CP - 160 (mm) (optional)

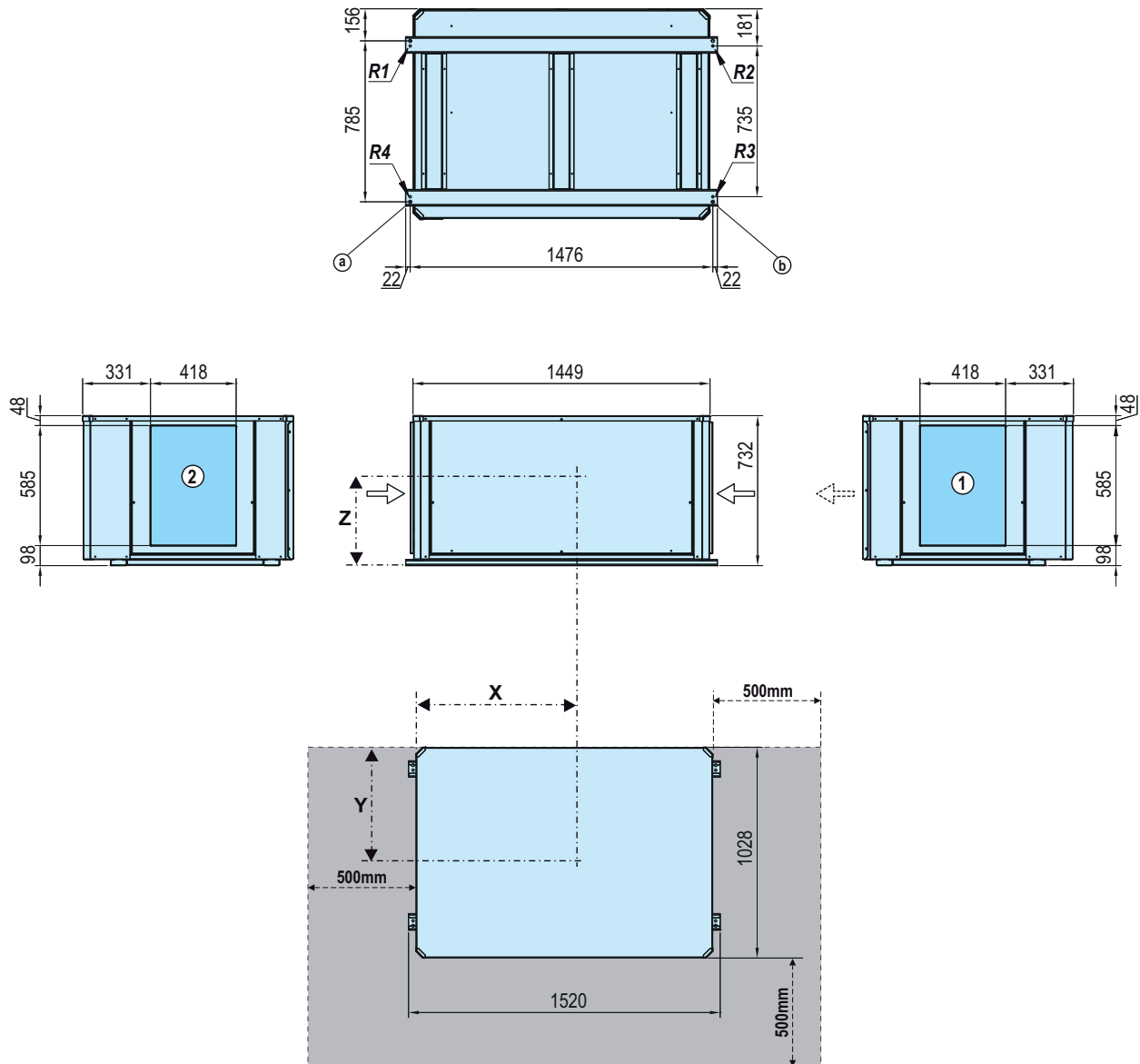

LEGEND

⇒ Indoor circuit air circulation

① Return in MS304 and new air inlet in MS403

② New air inlet in MS304 and return in MS403

a: Antivibration anchoring: rivet nut M8

b: Ceiling anchoring: threaded rod \varnothing 15mm

Clear space to be observed for maintenance operations and unit start-up

MFHA module		Centre of gravity (mm)			Reactions in the supports (kg)				
		X	Y	Z	Weight	R1	R2	R3	R4
160	MS304 MS403	723	465	327	118	26	26	33	33

Horizontal box (MFHA module) for CP - 182, 200 and 240 (mm) (optional)

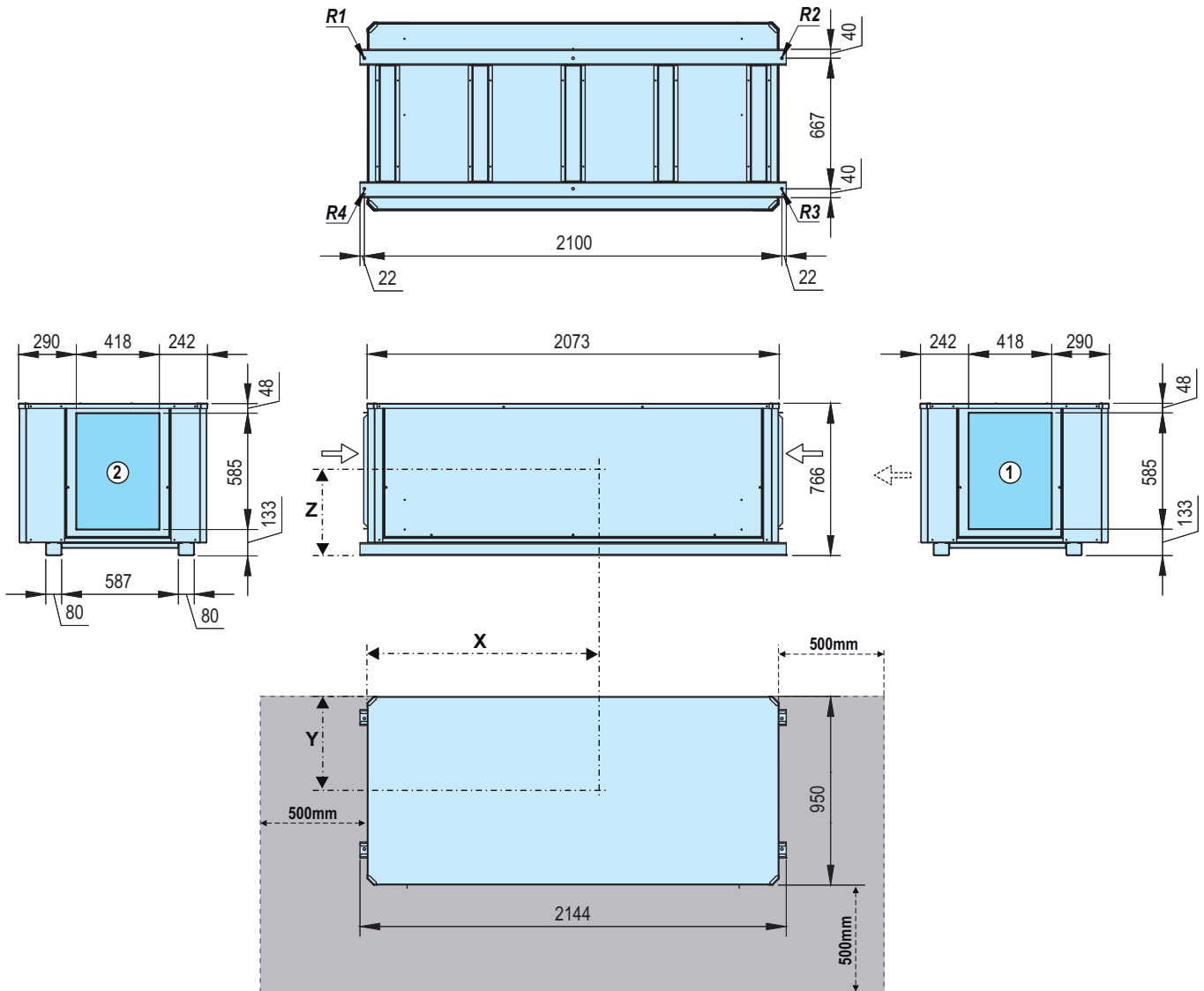

LEGEND	
	Indoor circuit air circulation
①	Return in MS304 and new air inlet in MS403
②	New air inlet in MS304 and return in MS403
Antivibration anchoring: rivet nut M10	
	Clear space to be observed for maintenance operations and unit start-up

MFHA module	Centre of gravity (mm)			Reactions in the supports (kg)					
	X	Y	Z	Weight	R1	R2	R3	R4	
182 200 240	MS304 MS403	1030	514	327	152	34	33	42	43

Horizontal box (MFHA module) for CP - 280, 320 and 360 (mm) (optional)

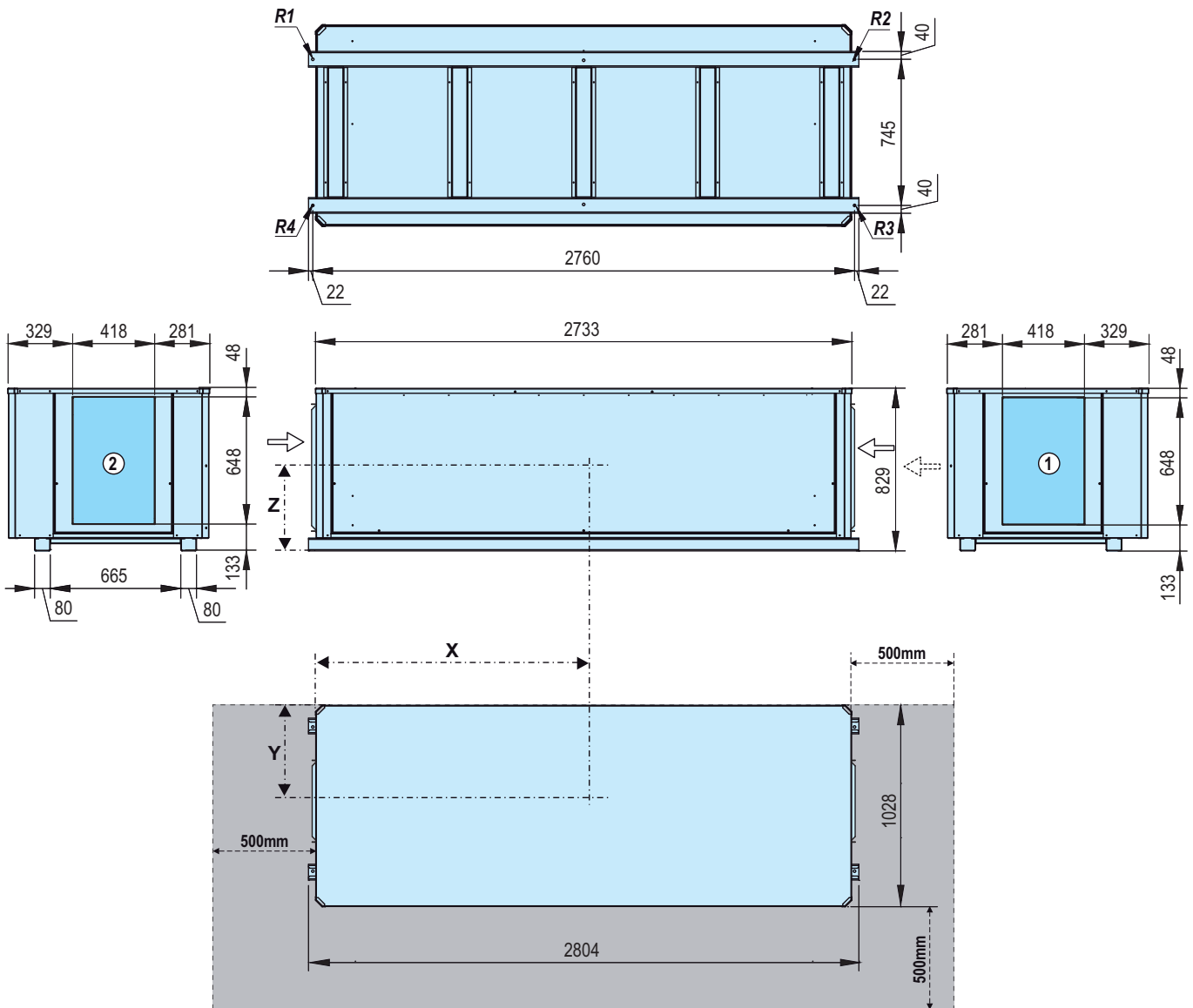

LEGEND

⇒ Indoor circuit air circulation

① Return in MS304 and new air inlet in MS403

② New air inlet in MS304 and return in MS403

Antivibration anchoring: rivet nut M10

Clear space to be observed for maintenance operations and unit start-up

MFHA module	Centre of gravity (mm)			Reactions in the supports (kg)					
	X	Y	Z	Weight	R1	R2	R3	R4	
280 320 360	MS304 MS403	1360	557	360	200	44	44	56	56

DIMENSIONS SCHEMES: SUPPLY PLENUM (OPTIONAL)

Supply plenum for CP - 90, 100, 120 and 160 (mm)

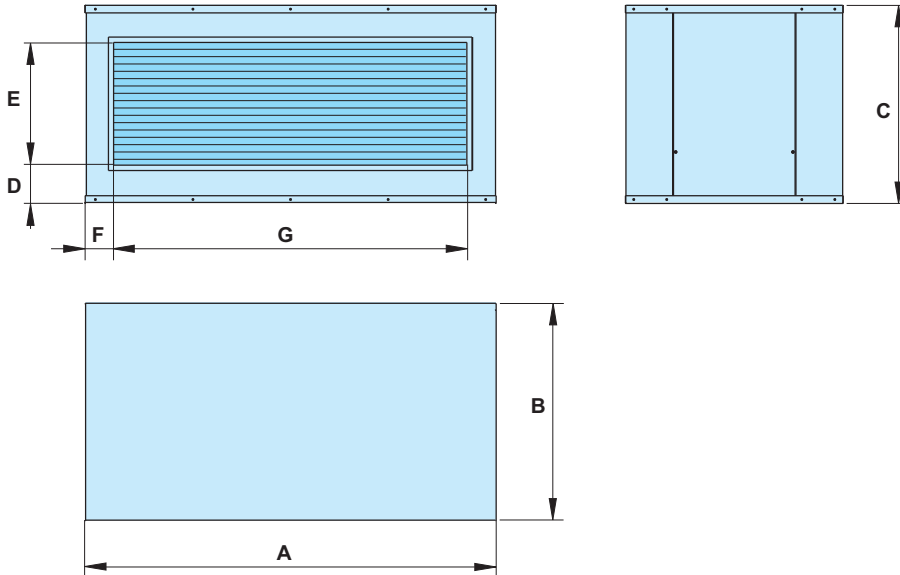

Supply plenum for CP - 182, 200, 240, 280, 320 and 360 (mm)

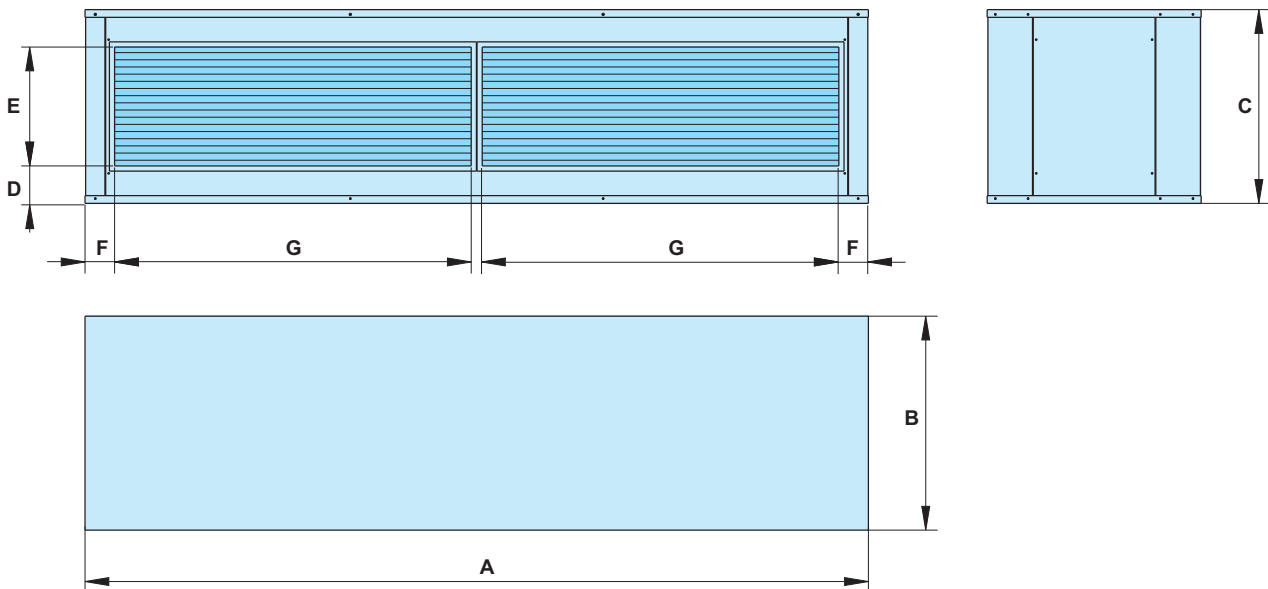

CP	Outdoor dimensions (mm)			Punched or double deflection grille (mm)			
	A	B	C	D	E	F	G
90 / 100 / 120	1057	720	655	107	440	121	815
160	1387	720	655	107	440	121	1145
182 / 200 / 240	2007	720	655	107	440	121	815
280 / 320 / 360	2647	720	655	107	440	121	1145

Note: plenum allows air be supplied through either side.



По вопросам продаж и поддержки обращайтесь:

Архангельск (8182)63-90-72

Астана +7(7172)727-132

Белгород (4722)40-23-64

Брянск (4832)59-03-52

Владивосток (423)249-28-31

Волгоград (844)278-03-48

Вологда (8172)26-41-59

Воронеж (473)204-51-73

Екатеринбург (343)384-55-89

Иваново (4932)77-34-06

Ижевск (3412)26-03-58

Казань (843)206-01-48

Калининград (4012)72-03-81

Калуга (4842)92-23-67

Кемерово (3842)65-04-62

Киров (8332)68-02-04

Краснодар (861)203-40-90

Красноярск (391)204-63-61

Курск (4712)77-13-04

Липецк (4742)52-20-81

Магнитогорск (3519)55-03-13

Москва (495)268-04-70

Мурманск (8152)59-64-93

Набережные Челны (8552)20-53-41

Нижний Новгород (831)429-08-12

Новокузнецк (3843)20-46-81

Новосибирск (383)227-86-73

Орел (4862)44-53-42

Оренбург (3532)37-68-04

Пенза (8412)22-31-16

Пермь (342)205-81-47

Ростов-на-Дону (863)308-18-15

Рязань (4912)46-61-64

Самара (846)206-03-16

Санкт-Петербург (812)309-46-40

Саратов (845)249-38-78

Смоленск (4812)29-41-54

Сочи (862)225-72-31

Ставрополь (8652)20-65-13

Тверь (4822)63-31-35

Томск (3822)98-41-53

Тула (4872)74-02-29

Тюмень (3452)66-21-18

Ульяновск (8422)24-23-59

Уфа (347)229-48-12

Челябинск (351)202-03-61

Череповец (8202)49-02-64

Ярославль (4852)69-52-93

сайт: www.ciat.nt-rt.ru | эл. почта: cta@nt-rt.ru